

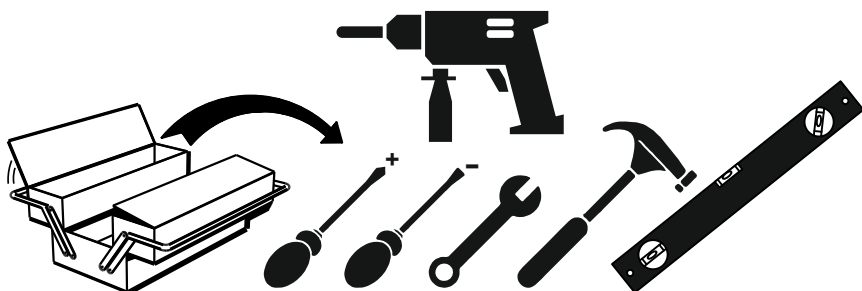

MULTIMO

721-PRIMER HAPPY 721-M OPTIONEL DESK

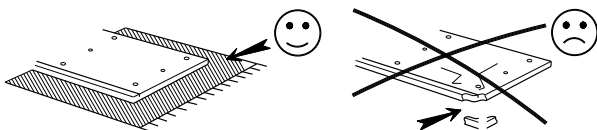

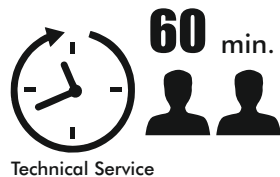
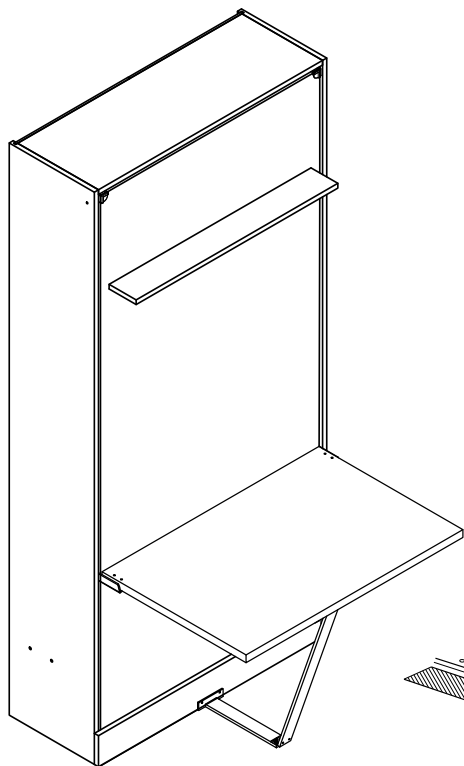









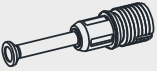

VIDEO

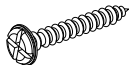
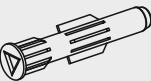
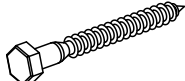
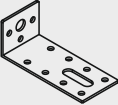

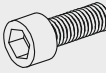
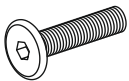
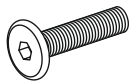
https://youtu.be/ZMz5_3J-3p0

Track Title	Piece	(inch)			(mm)			
		Thickness	Length	Width	Piece	Thick	Height	Most
A-R / A-L		0,71	87,01	14,96	2	18	2210	380
B		0,71	39,37	14,17	1	18	1000	360
C		0,71	39,37	14,96	1	18	1000	380
D		0,71	39,37	10,24	1	18	1000	260
E		0,71	40,79	4,65	1	18	1036	118
F		0,71	35,43	4,72	1	18	900	120
G		0,71	82,68	38,50	1	18	2100	978
H		0,31	86,61	19,96	2	8	2200	507
K		0,71	39,37	10,24	1	18	1000	260
M-R / M-L		0,71	81,34	5,91	2	18	2066	150
N		0,71	35,59	5,91	2	18	904	150

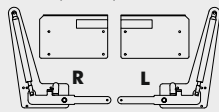
Accessories List

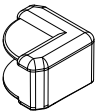
MNX 02  50 / piece	MNG - 01  50 / piece	KVL 01  42 / piece	TAP - 01  50 / piece
VD - 02 (3,5x25) mm  8 / piece	DD - 01 (R10)  2 / piece	TFC - 01(8x70) mm  2 / piece	DSE - 01 (40x90x32) mm  2/ piece
PL - 02 (8x22x1) mm  2 / piece	VTB - 01 (4,8x16) mm  12/ piece	IM - 02 (6x20) mm  4 / piece	CT - 04 (6x20) mm  8 / piece
CT - 02 (6x30) mm  2 / piece	OT-054  2 / piece	PL - 04 (5x12x0,7) mm  4 / piece	VDA - 01 (6,5x50) mm  12 / piece
HF - 01 (950 N)  1 / piece	YKR - 01  1 / piece	H 01  1 / piece	KKS - 01  2 / piece

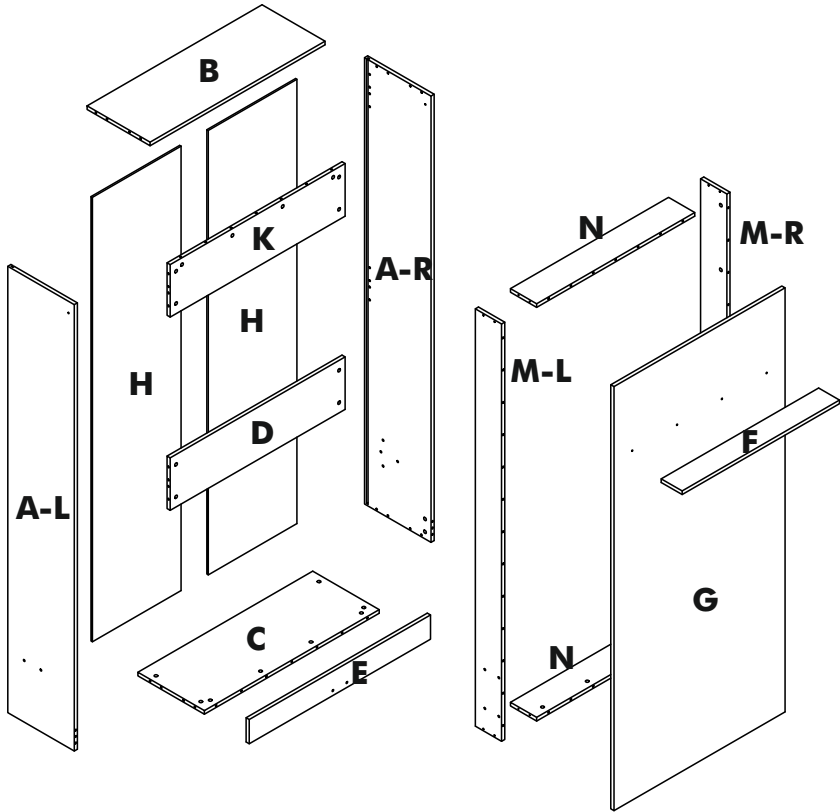

STEP 1

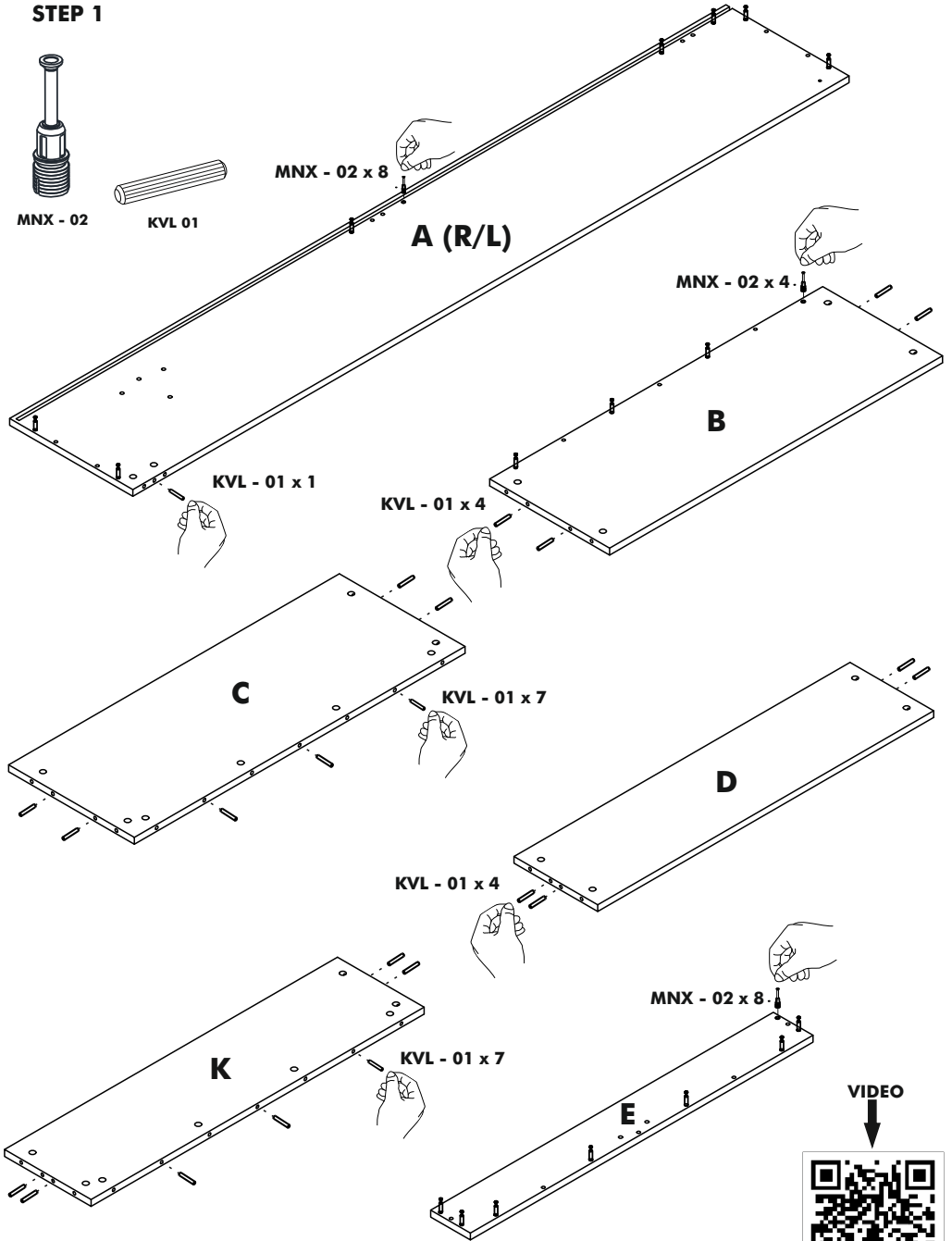
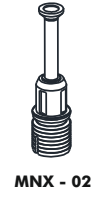

VIDEO



STEP 2

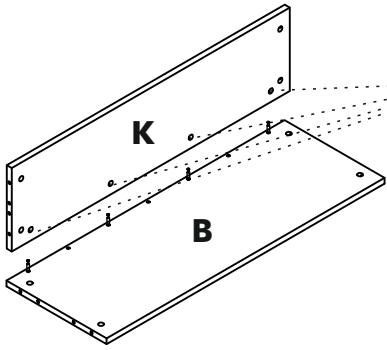
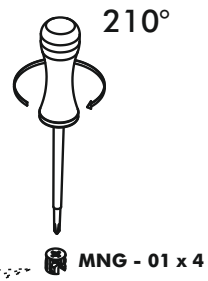

STEP 3

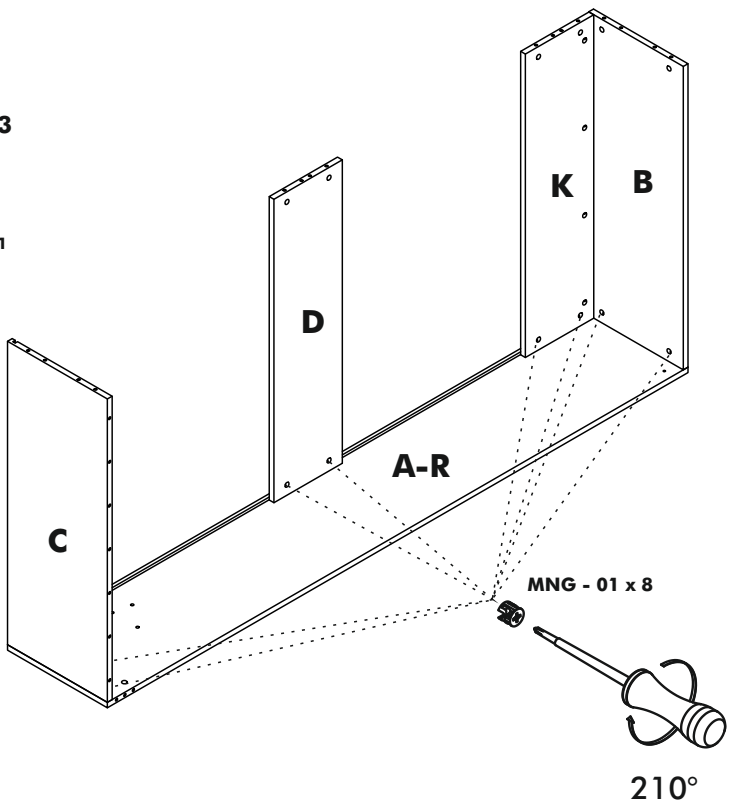

STEP 4

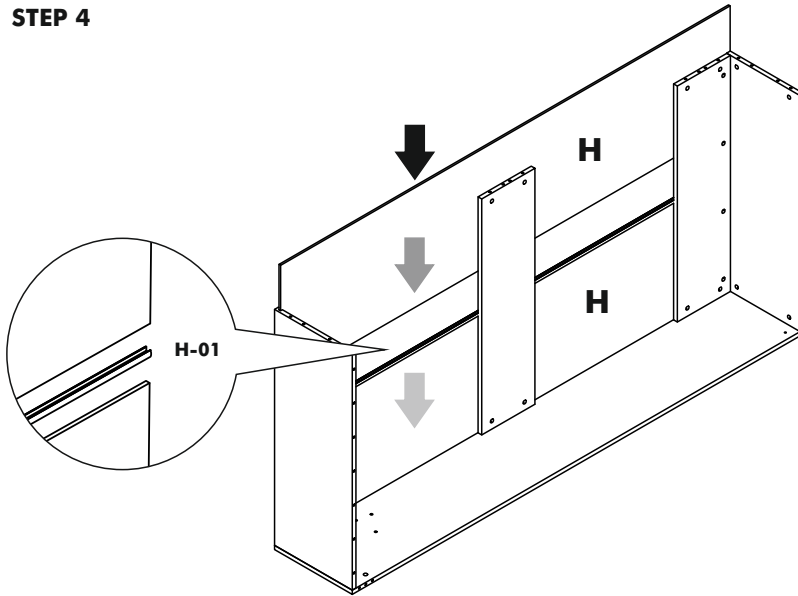

STEP 5

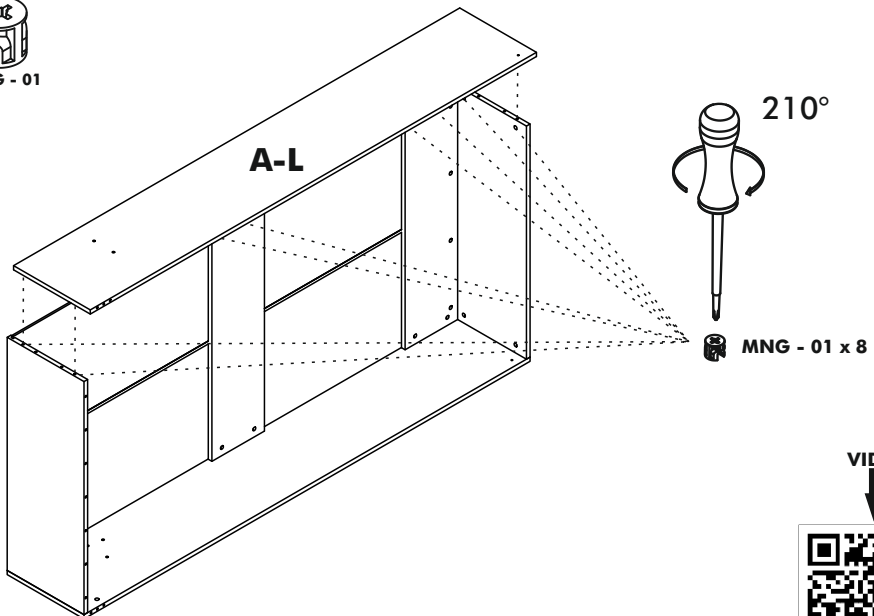

STEP 6

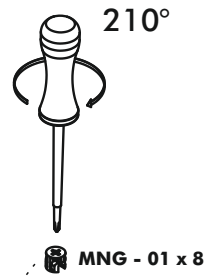
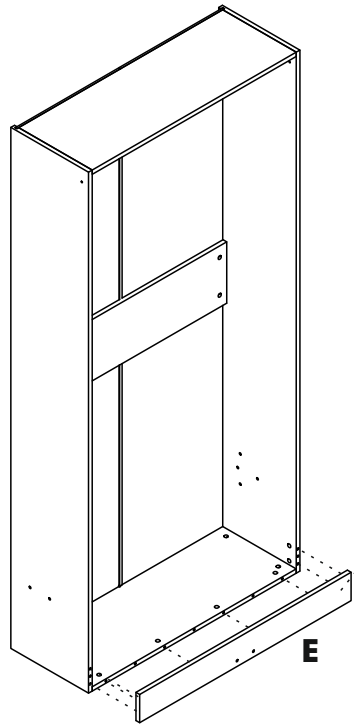

STEP 7

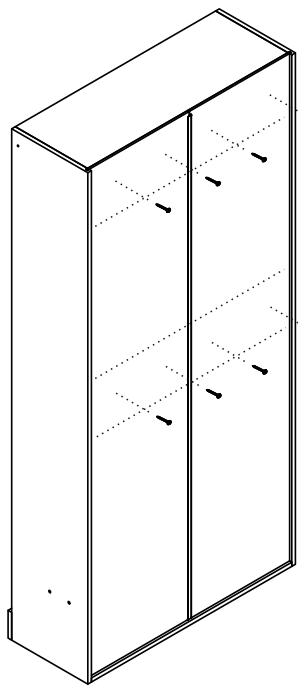

VIDEO



STEP 8

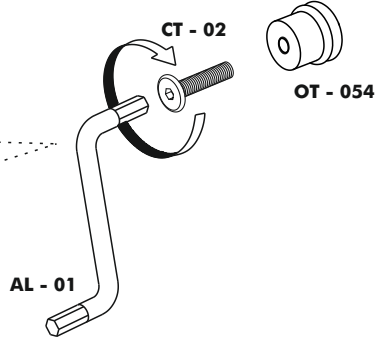
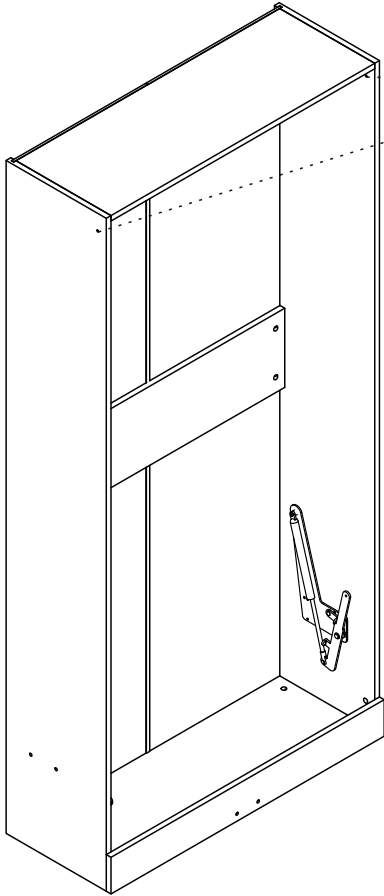

STEP 9

CAUTION
DO NOT UNLOCK
BEFORE INSTALL

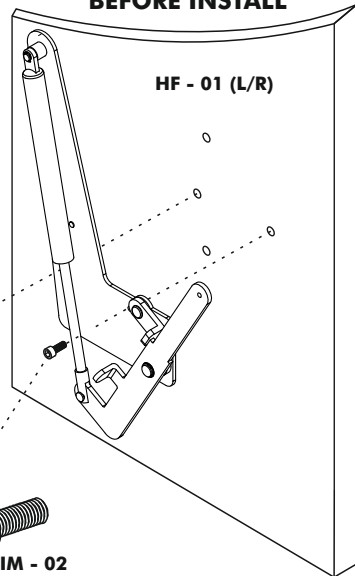

Remove the screw
Vidayı çıkarın

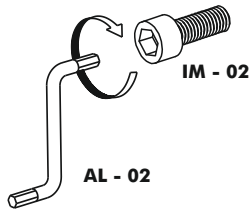
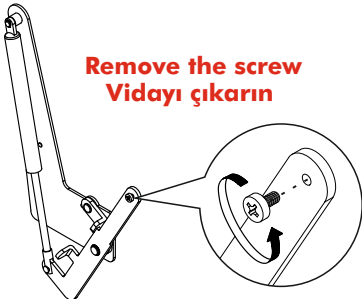

VIDEO



STEP 10



Ø 10 mm / 0,254 inch

DD - 01

PL - 02

TFC - 01

VTB - 01

DSE - 01

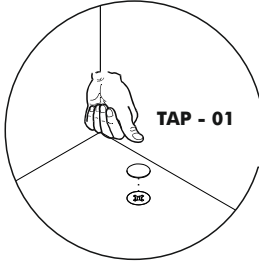
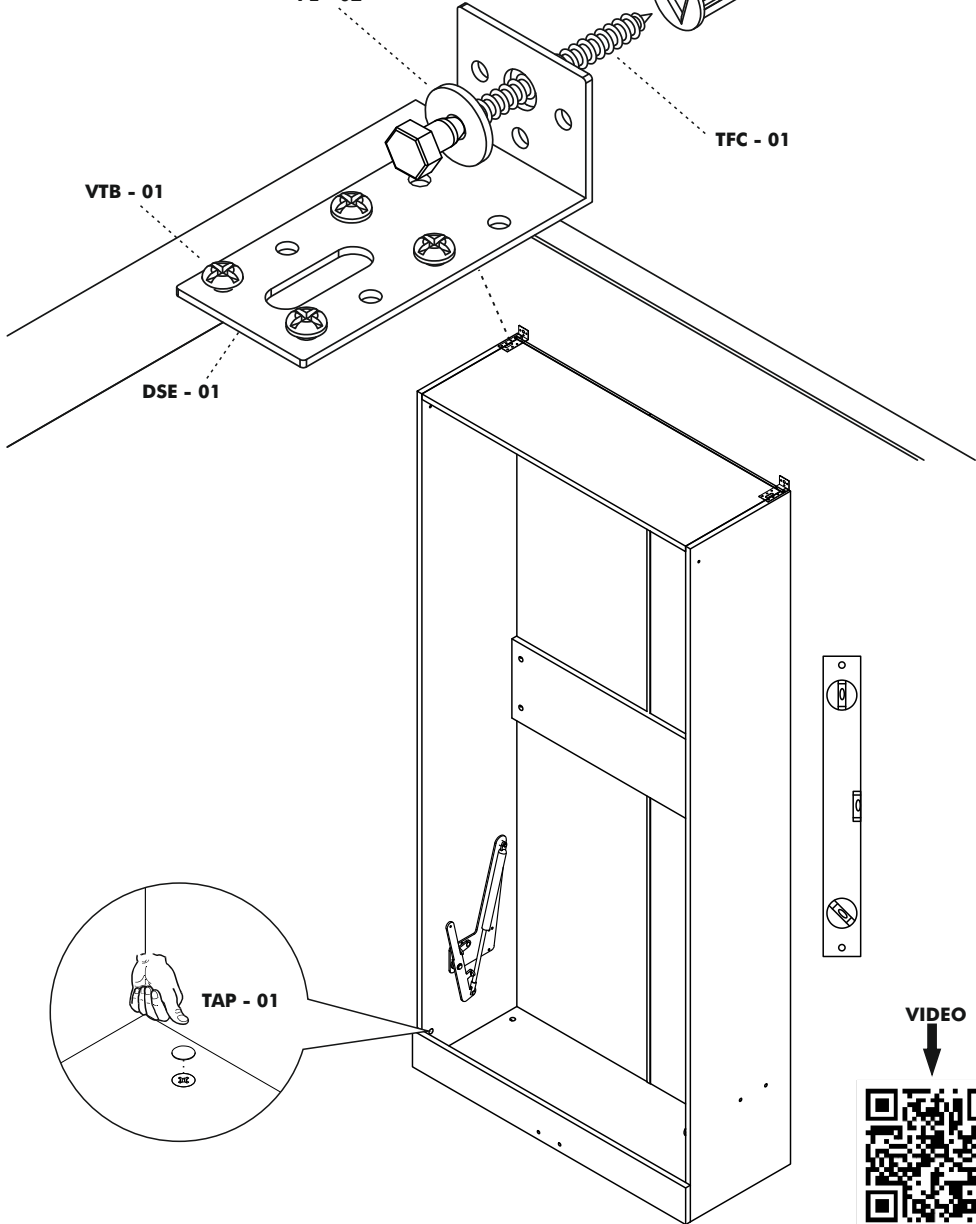

TAP - 01

VIDEO



STEP 11



MNX - 02

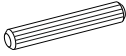

KVL 01

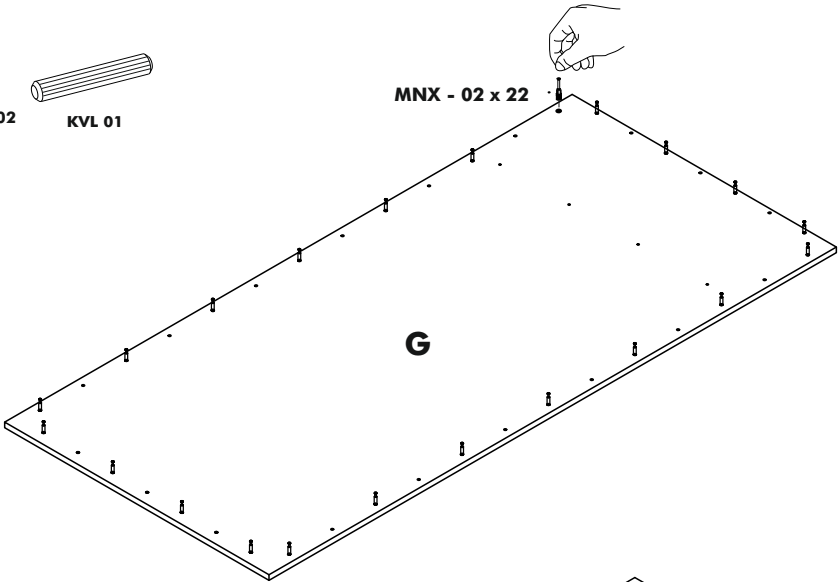

M-(R/L)

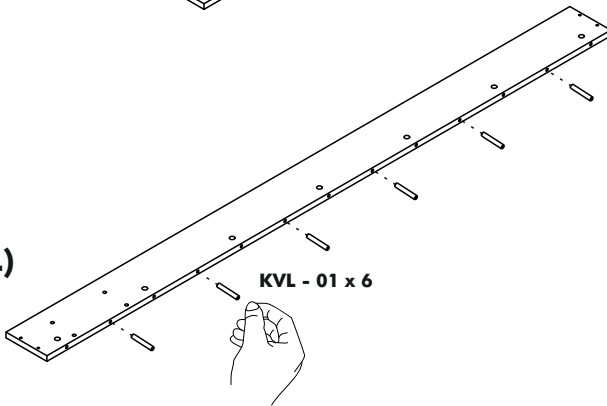

N

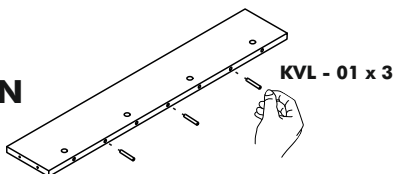

VIDEO



<https://youtu.be/H1qk-pRvkDQ>

STEP 12

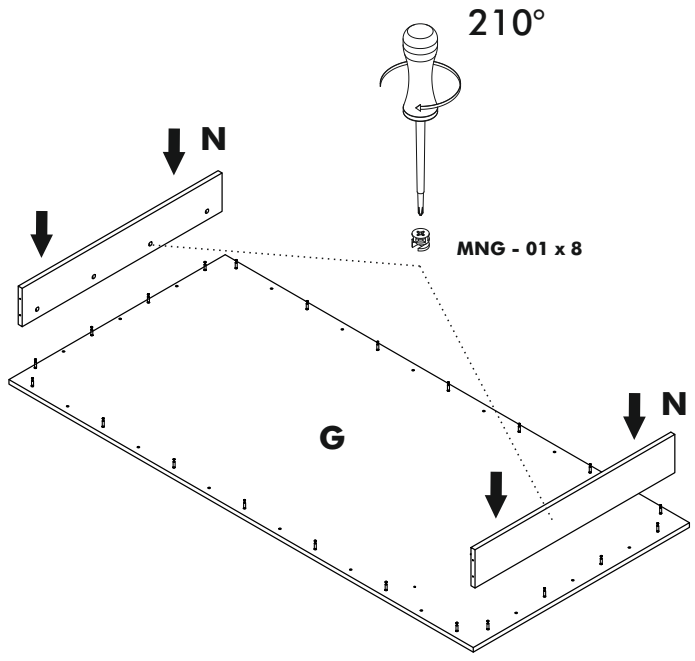

STEP 13

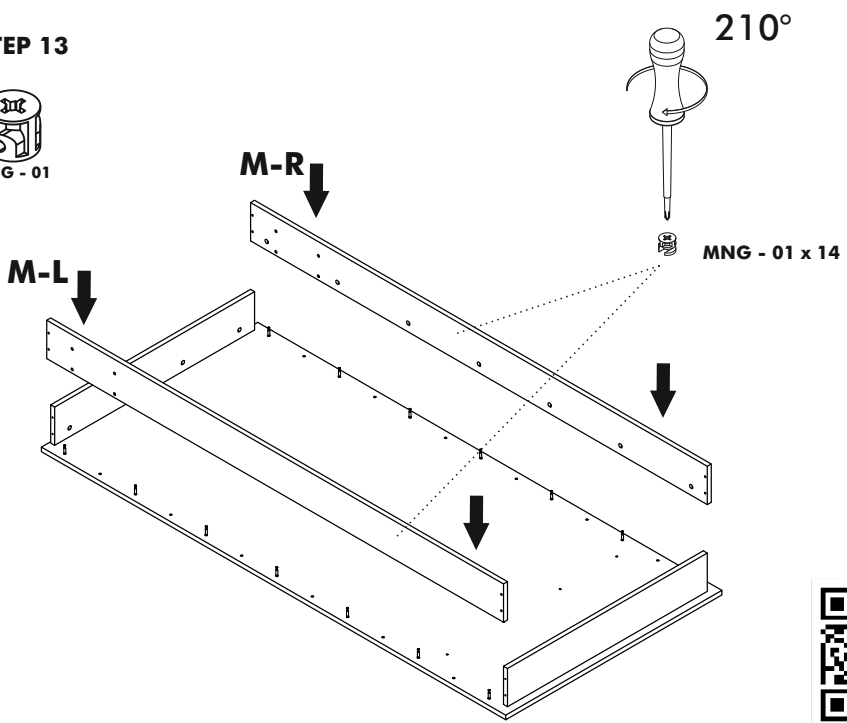

VIDEO



STEP 14

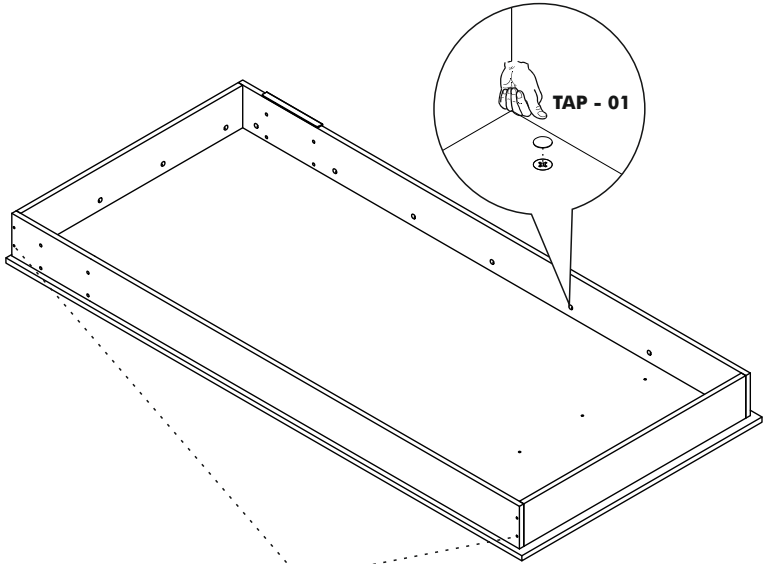

VDA - 01 X 8

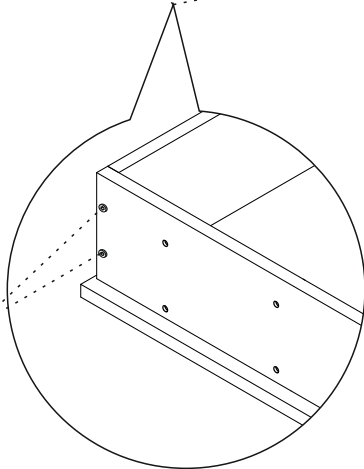
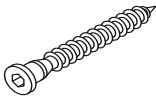

VIDEO



<https://youtu.be/CQfKoQ8wZ6U>

STEP 15

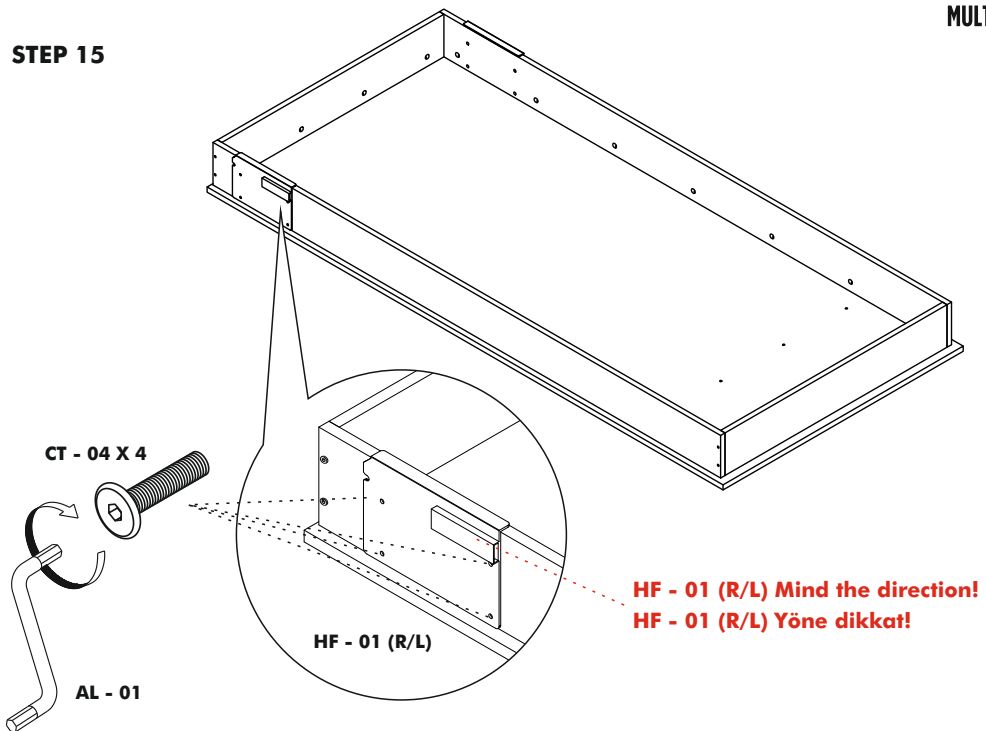

STEP 16

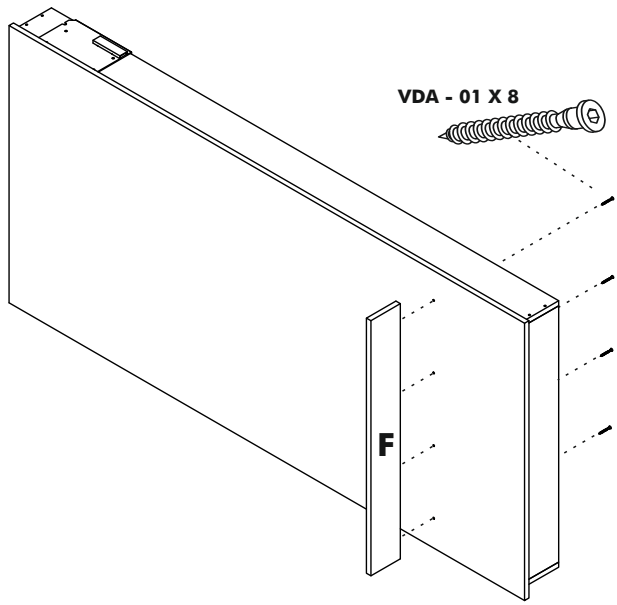

VIDEO



<https://youtu.be/C7LtChlku9M>

STEP 17



**KAPAK KAPATILMADAN KİLİDİ İNDİRİN !!!
LET THE STOPPER LOCK MOVE DOWN !!!**

STEP 18

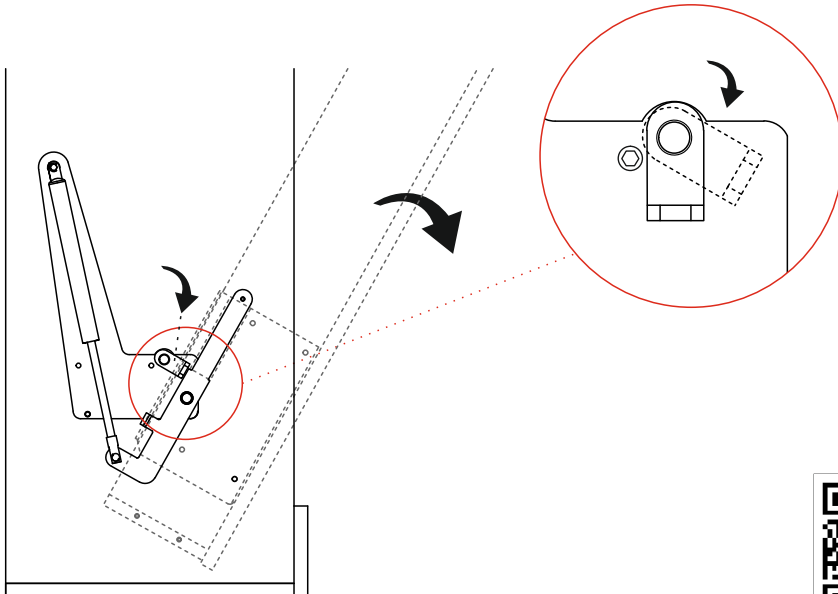

VIDEO



<https://youtu.be/n-8Uj4SszZg>

STEP 19

STEP 20

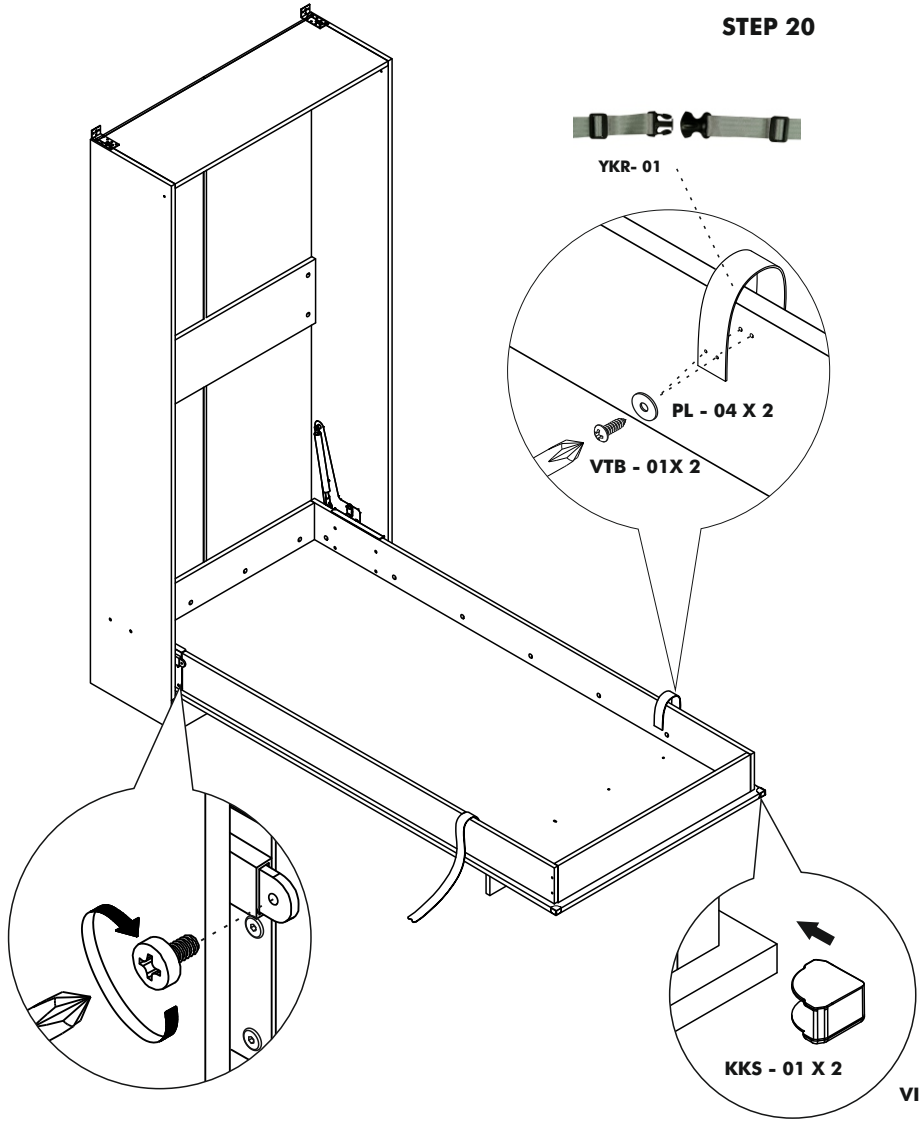

**SABİTLEME VİDASINI TAKINIZ !!!
PLEASE INSERT THE FIXING SCREW !!!**

VIDEO









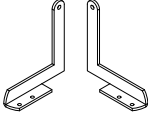
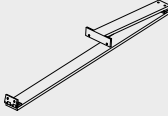
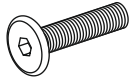

<https://youtu.be/ByITzImdXZE>

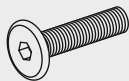
OPTIONEL DESK

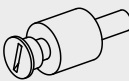
Track Title	Piece	(inch)			(mm)			
		Thickness	Length	Width	Piece	Thick	Height	Most
P	1	1,18	38,50	25,59	1	30	978	650

Accessories List

SC - 49  2 / piece	LM-03  1 / piece	CT - 08 (6x25) mm  2 / piece	HB - 03 (6x14) mm  2 / piece
CT - 01 (6x40) mm  4 / piece	PL - 02 (8x22x1) mm  2 / piece	OT 10  2 / piece	SN - 02 (M8)  2 / piece
SN - 01 (M6)  4 / piece	PL - 01 (6x19x1) mm  4 / piece		

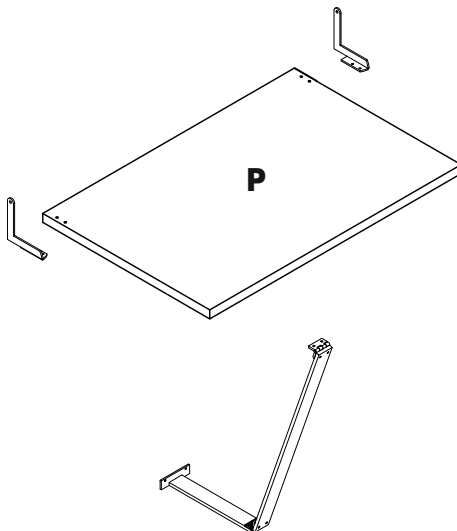

STEP 1

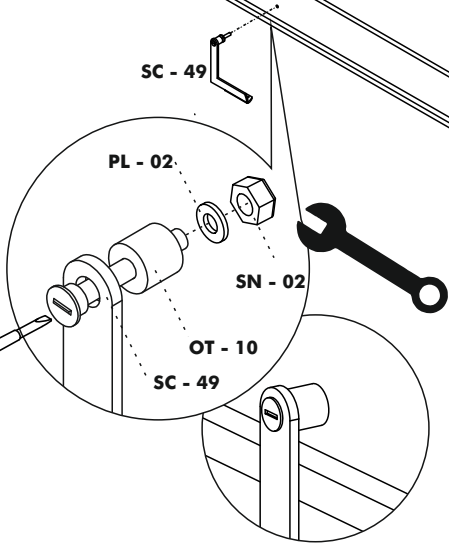
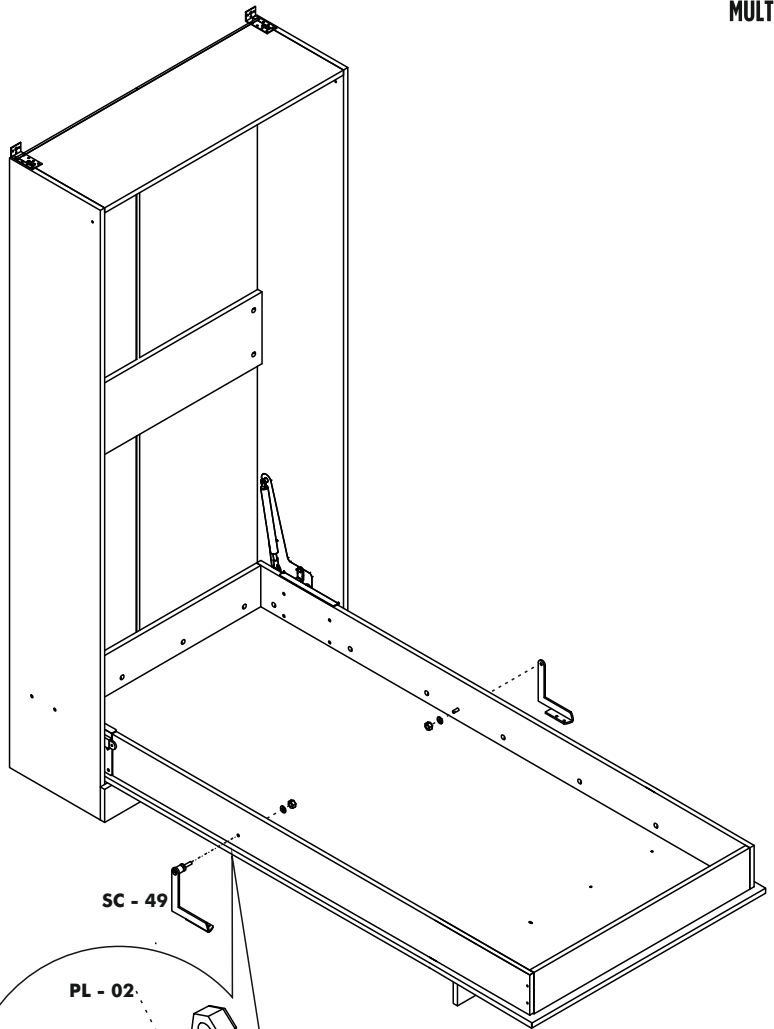

VIDEO



<https://youtu.be/J80jTgly7Kc>

STEP 2

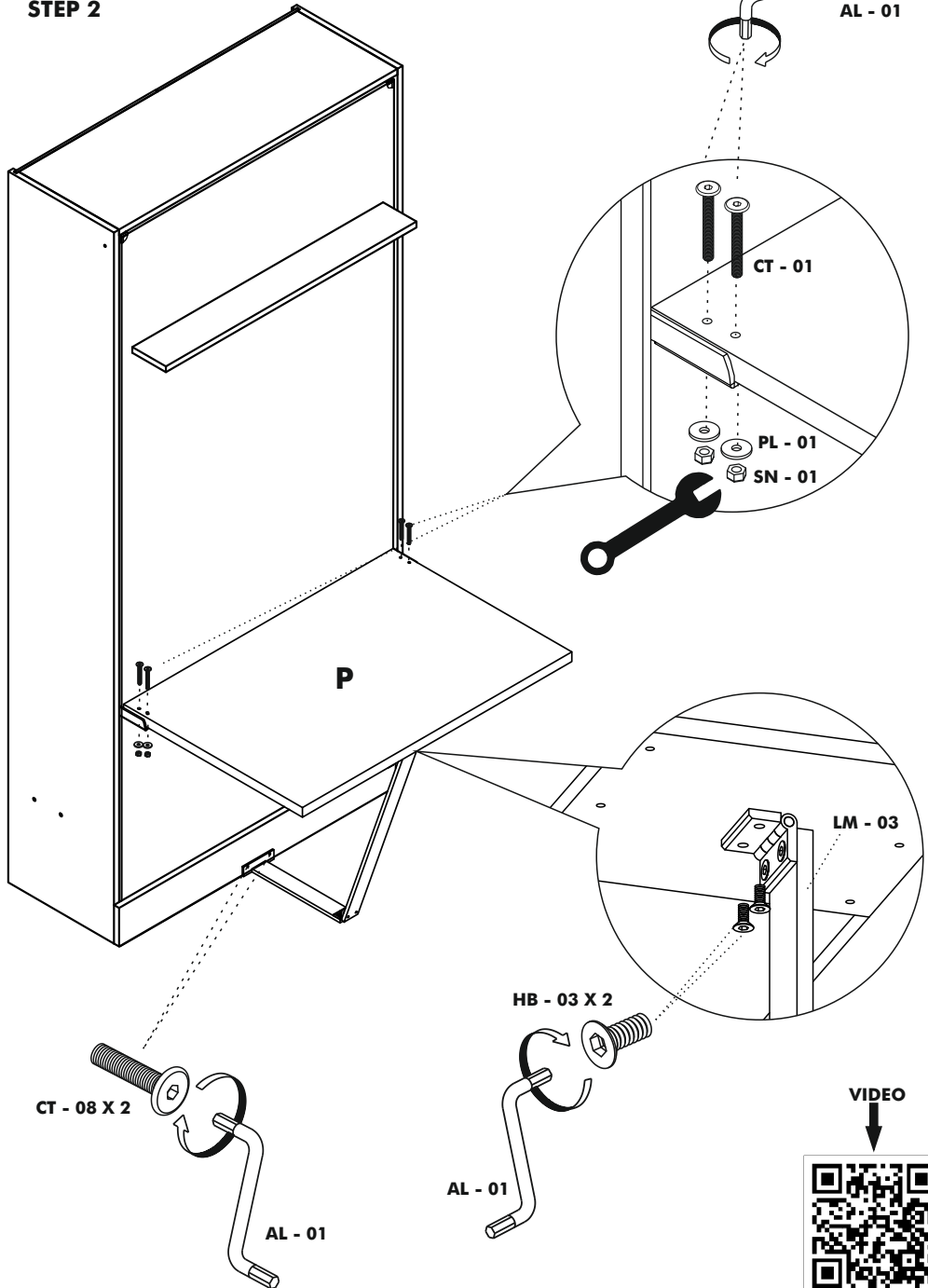

VIDEO



ATTENTION / HOW TO / READ ME / OWNER'S GUIDE

1. When mounting on a regular drywall, furniture must be fastened to wood or metal studs. Solid walls made of brick, concrete or similar strong material are also acceptable. Do not mount furniture to paper-mache or sheetrock (plasterboard) like material without properly fixing to stud.
2. For safety and product longevity you must periodically inspect the mounting and mechanical connections for integrity and tightness. Confirm hardware remains properly affixed and connections snug.
3. Wall Bed mattress thickness may not exceed 8 inches (200mm). Take care to remove pillows and excess blankets before closing. Doing so keeps mechanism free of obstruction and unnecessary stress.
4. Do not lean or rest heavy objects on side or top of furniture. This may cause balance issues and compromise the integrity of your mounting connections.
5. Please use the furniture's beds, desks and shelving as intended. Not designed to be sat, stood, leaned, jumped (etc) on. Improper use may cause personal injury and damage to property.
6. With seasonal humidity change you must inspect interior and exterior of furniture.
7. Single bed models are suitable for the weight of one person. Sleeping by more than one person will cause damage of the product.
8. Before any un-mounting or disassembly please contact Multimo for technical support and instruction. Failure to properly detach risks injury to person and damage to property.
9. For Bunk Beds:
 - a. Always use provided ladder when accessing top bunk.
 - b. Be slow, careful and aware of surroundings when opening top bunk.
 - c. Do not horseplay. Beds are to be slept on only.
 - d. Some have legs that fully extend when open- be aware of where the leg is and will be.



MULTiMO

www.multimo.com