

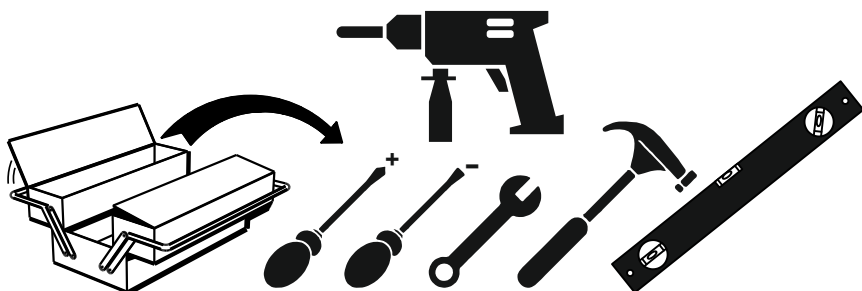

MULTIMO

630 - COMPACT

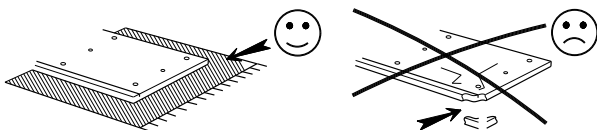

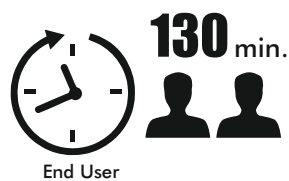
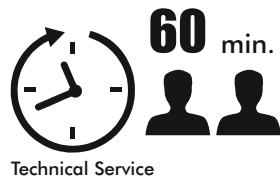
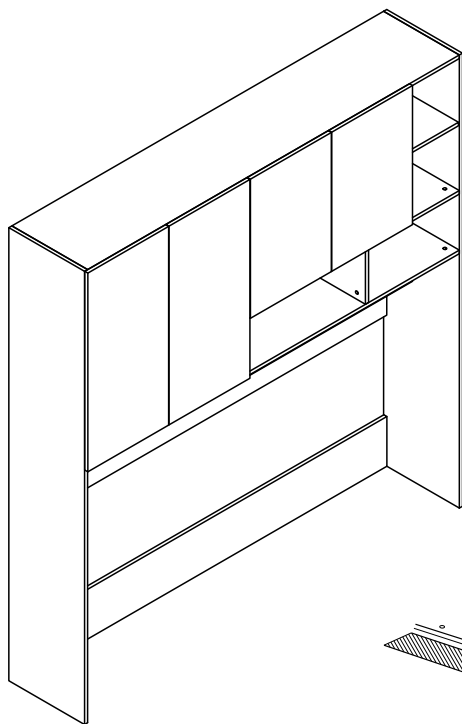

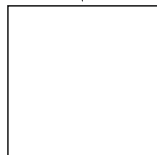





VIDEO

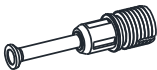

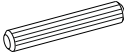
link

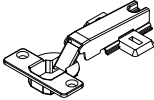
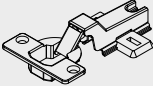
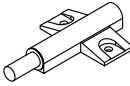
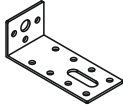
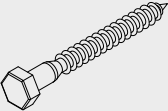
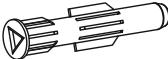
Track Title	Piece	(inch)			(mm)			
		Thickness	Length	Width	Piece	Thick	Height	Most
A-R / A-L		0,71	89,76	17,32	2	18	2280	440
B		0,71	85,04	17,32	1	18	2160	440
C		0,71	85,04	17,32	1	18	2160	440
D		0,71	37,95	16,54	1	18	964	420
E		0,71	26,14	16,54	1	18	664	420
F		0,71	11,10	16,54	1	18	282	420
G		0,71	48,23	16,54	1	18	1225	420
H		0,71	11,38	16,34	1	18	289	415
K		0,71	85,04	20,47	1	18	2160	520
L		1,18	85,04	5,91	1	30	2160	150
M		0,71	36,10	16,34	3	18	917	415
N		0,31	38,58	21,38	4	8	980	543
P		0,71	39,37	18,50	2	18	1000	470
R		0,71	27,56	18,50	2	18	700	470
S		0,71	85,04	9,84	1	18	2160	250

Accessories List

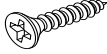
MXN 02  40 / piece	MNG - 01  40 / piece	KVL 01  44 / piece	TAP - 01  40 / piece
PM - 01  12 / piece	TS - 01  4 / piece	TS - 02  4 / piece	BS - 01  4 / piece
DSE - 01 (40x90x32) mm  3 / piece	TFC - 01(8x70) mm  3 / piece	DD - 01 (R10)  3 / piece	PL - 02 (8x22x1) mm  3 / piece
VTB - 01 (4,8x16) mm  12 / piece	AVT - 01  12 / piece	VD - 02 (3,5x25) mm  20 / piece	VD - 03 (3,5x18) mm  44 / piece

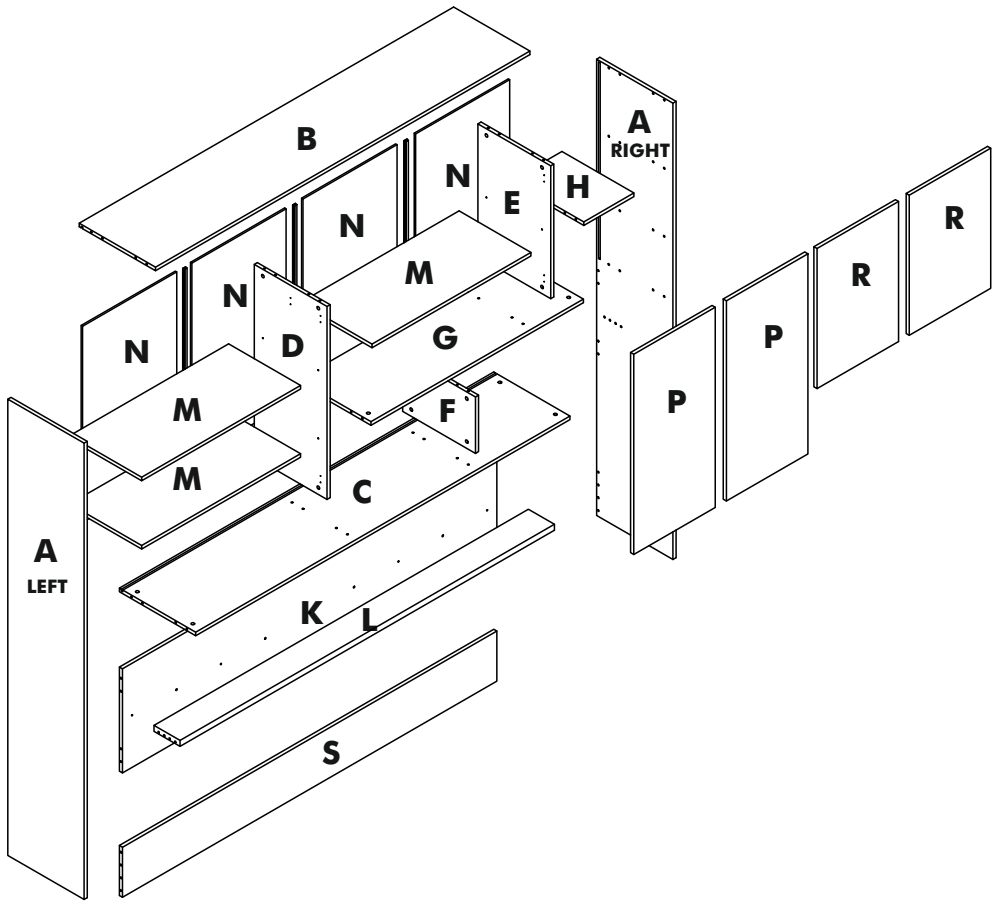

VDA - 01 (6,5x50) mm

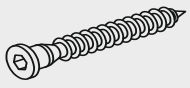

5 / piece

AF - 02



2 / piece

BO - 01

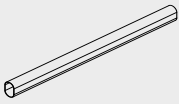

1 / piece

H 01

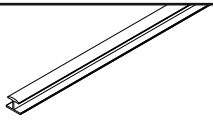

3 / piece

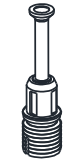
STEP 1

MNX - 02

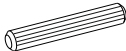

KVL 01

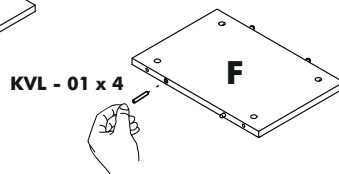
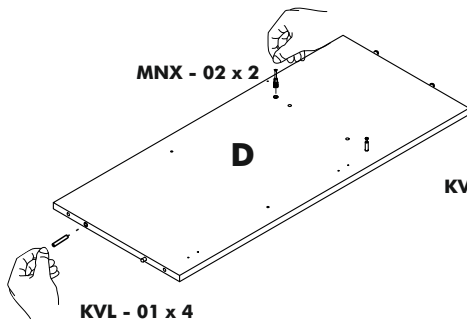
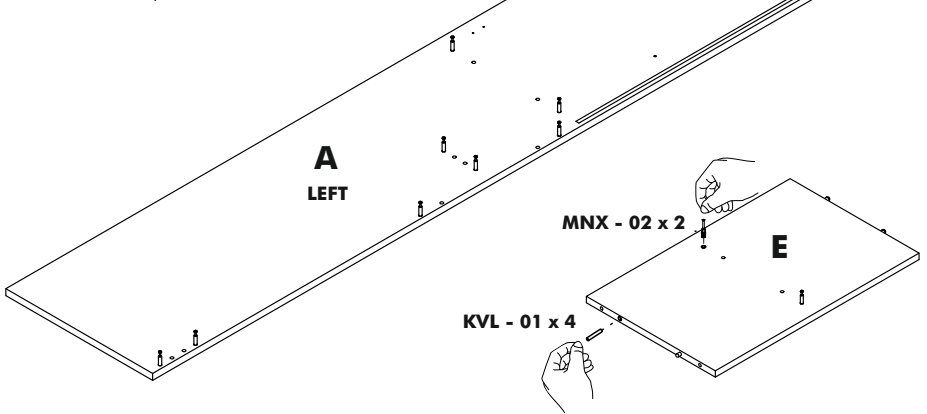
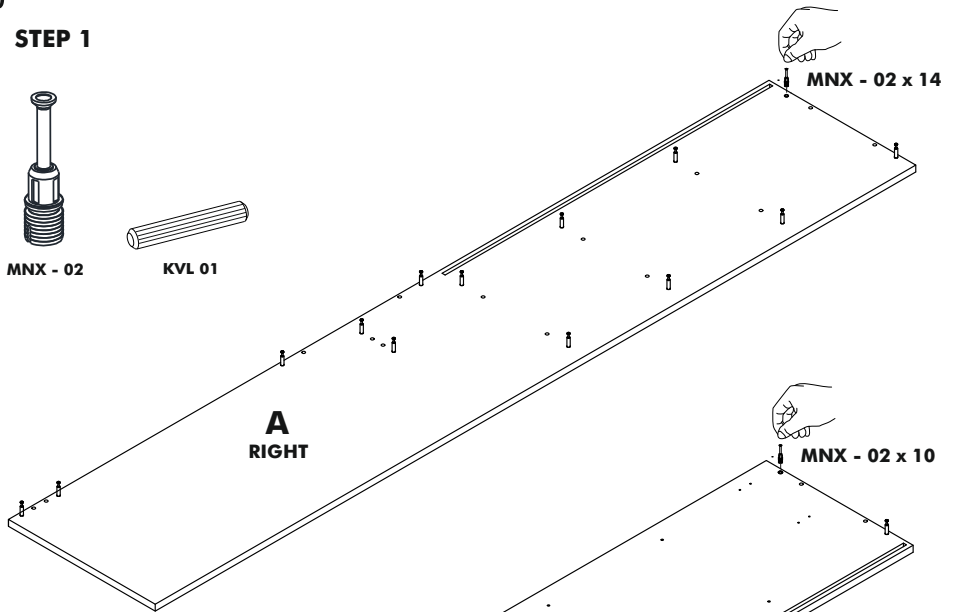
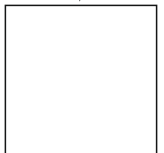
**VIDEO**

link

STEP 2

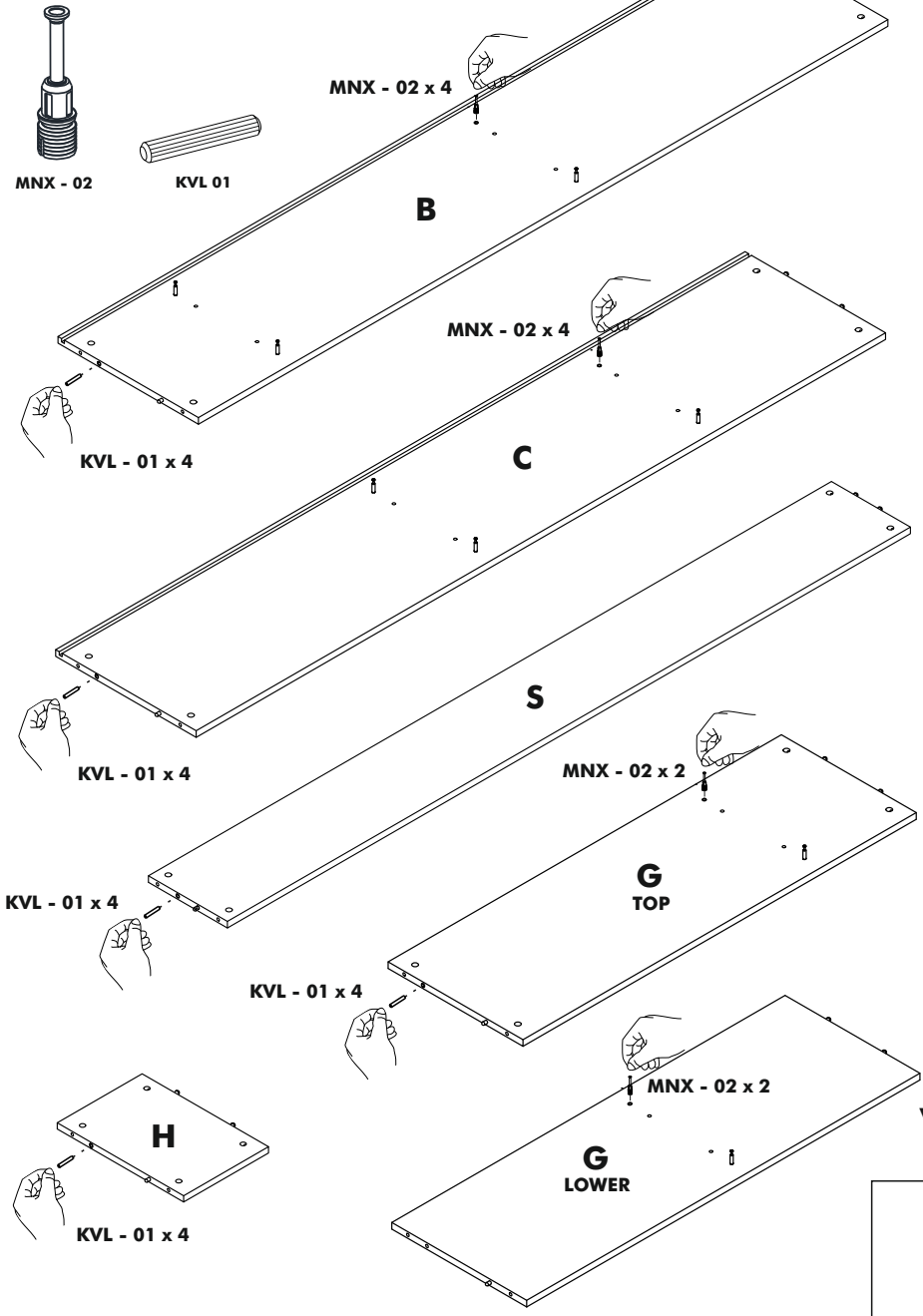

VIDEO

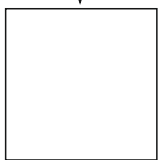

link

STEP 3

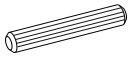

KVL 01

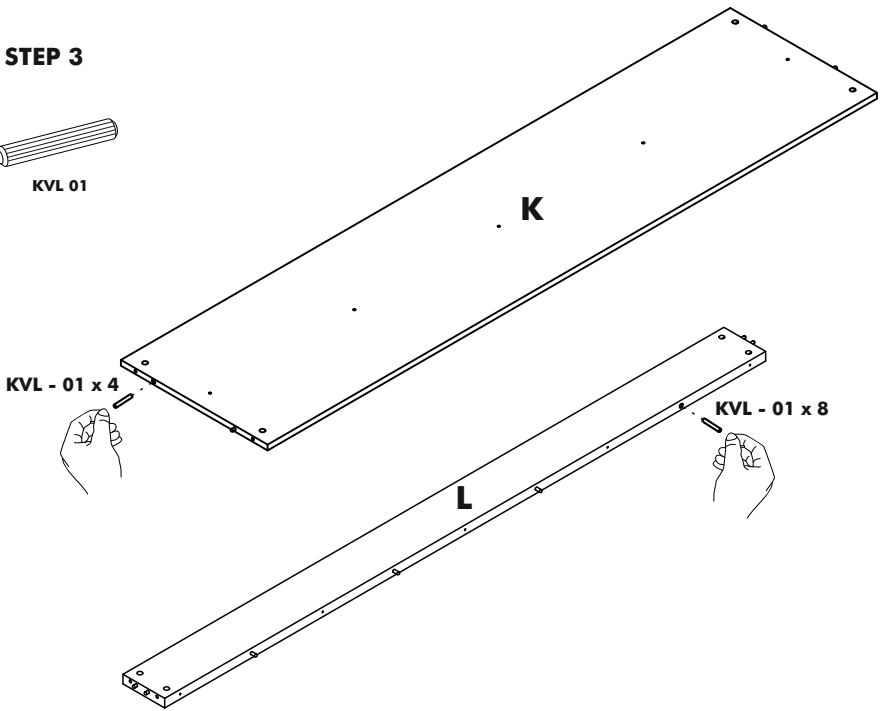

STEP 4

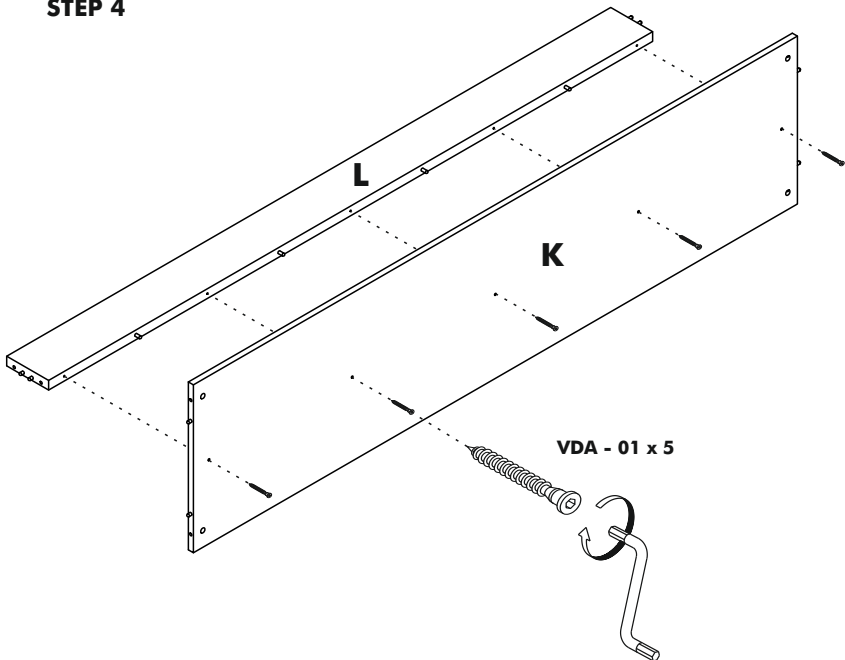

VIDEO

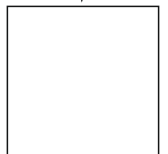

link

STEP 5

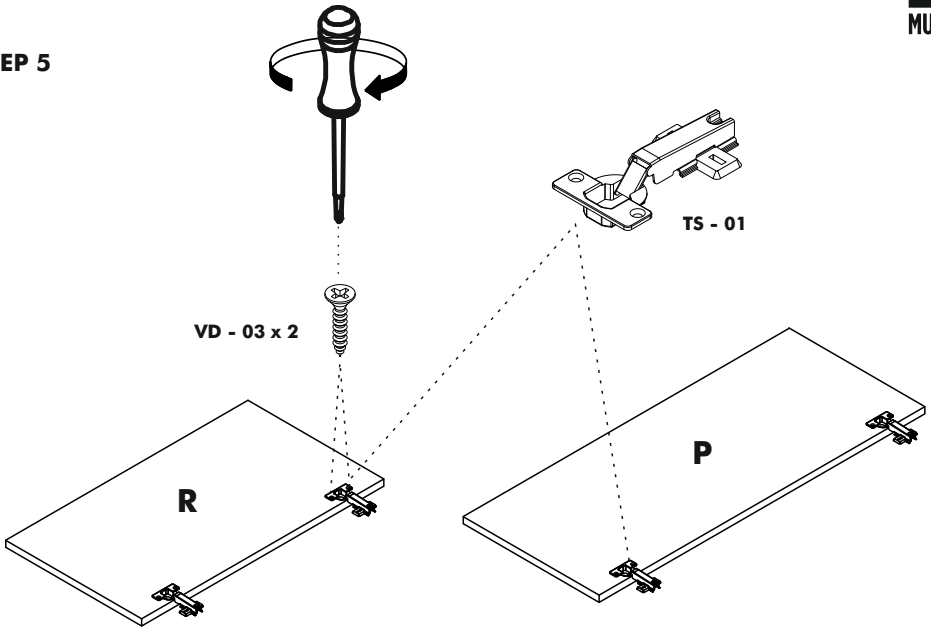

STEP 6

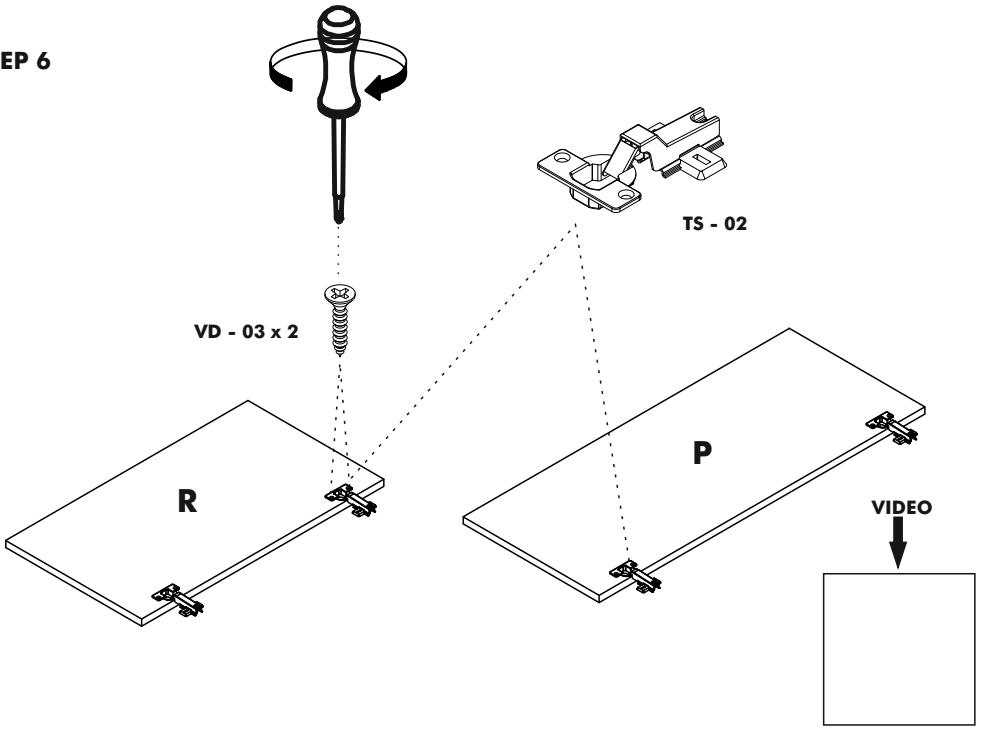

STEP 7

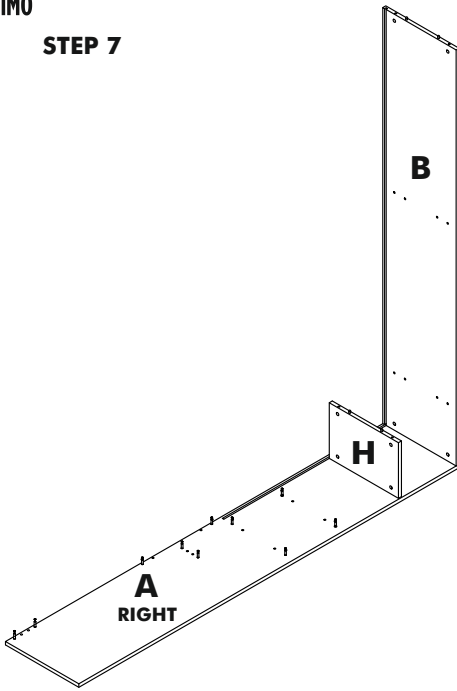

STEP 8

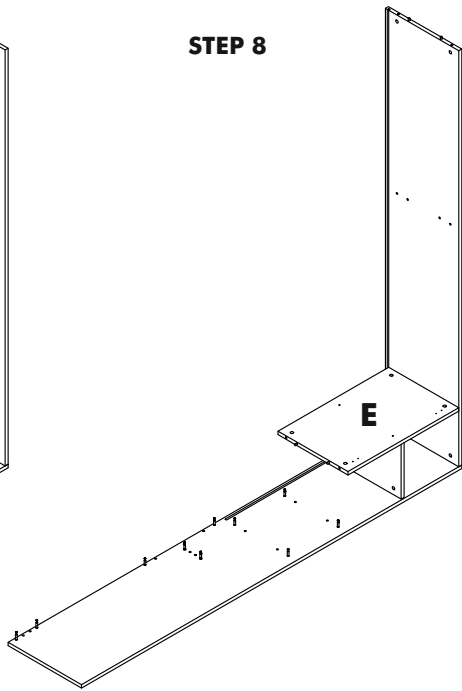

STEP 9

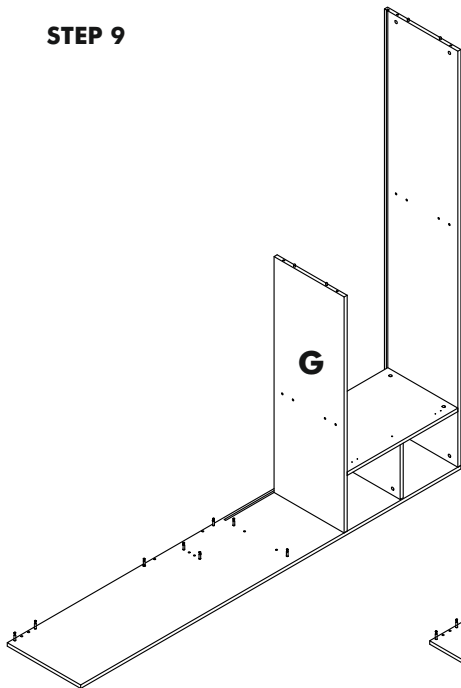

STEP 10

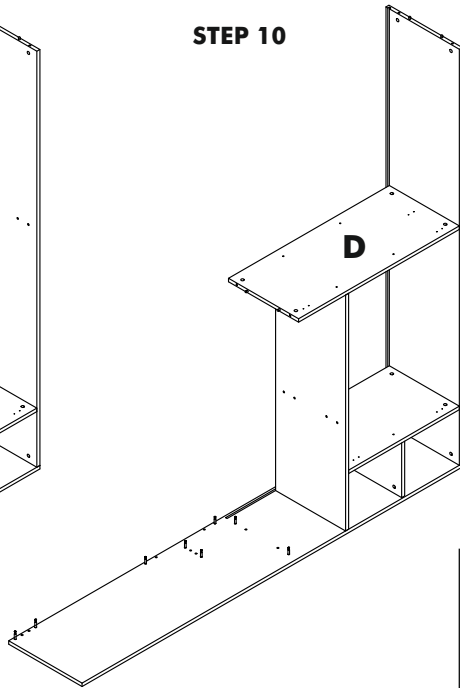

VIDEO

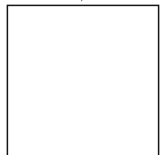

link

STEP 11

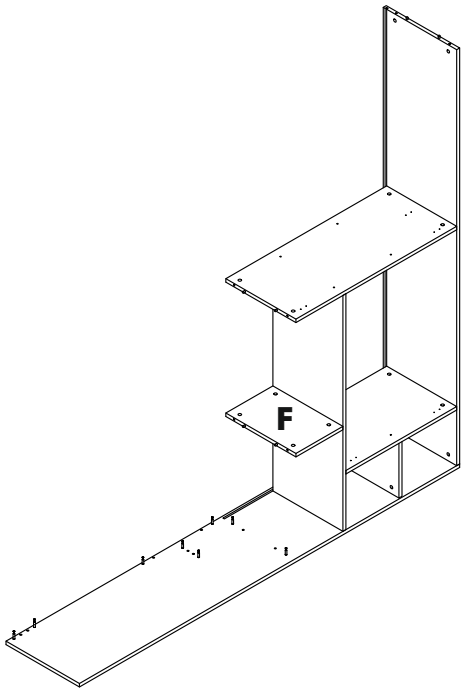

STEP 12

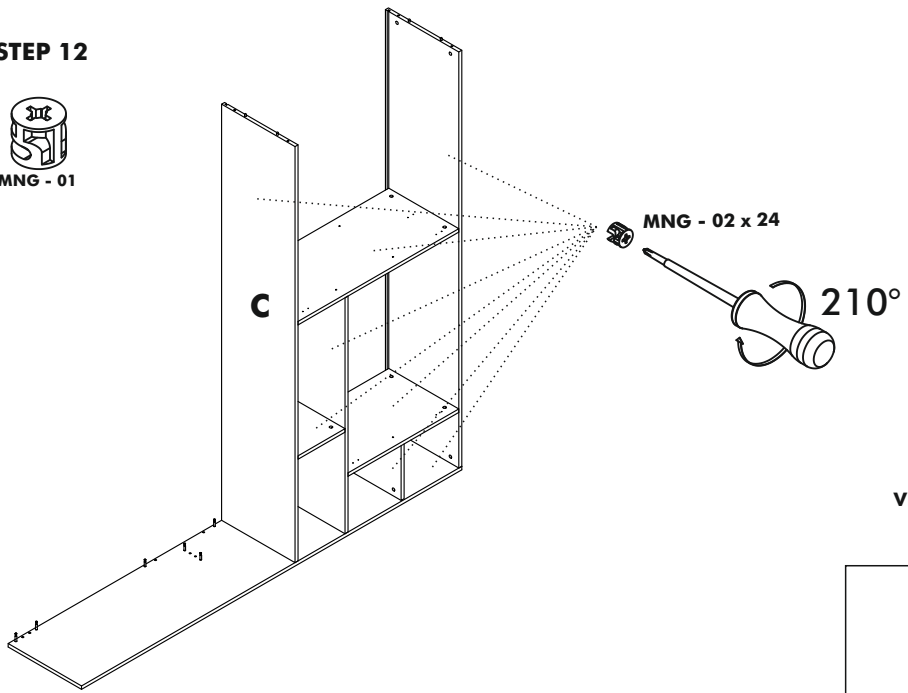

VIDEO

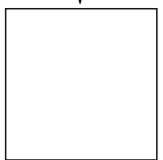

link

STEP 13



MNG - 01

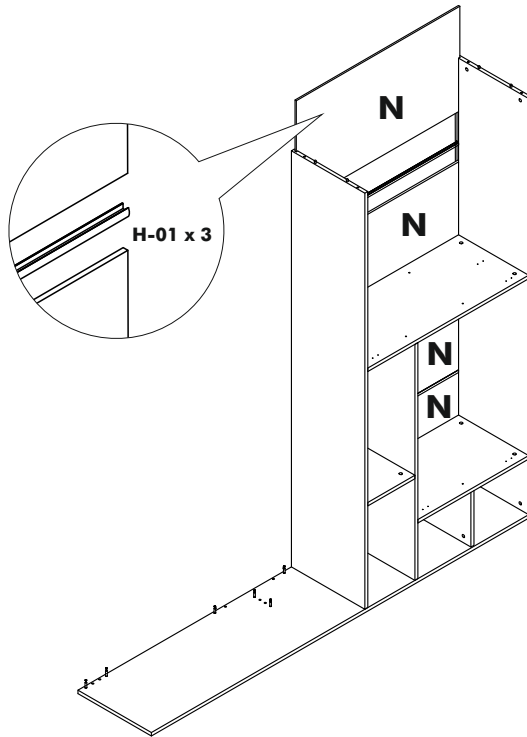

STEP 14



MNG - 01

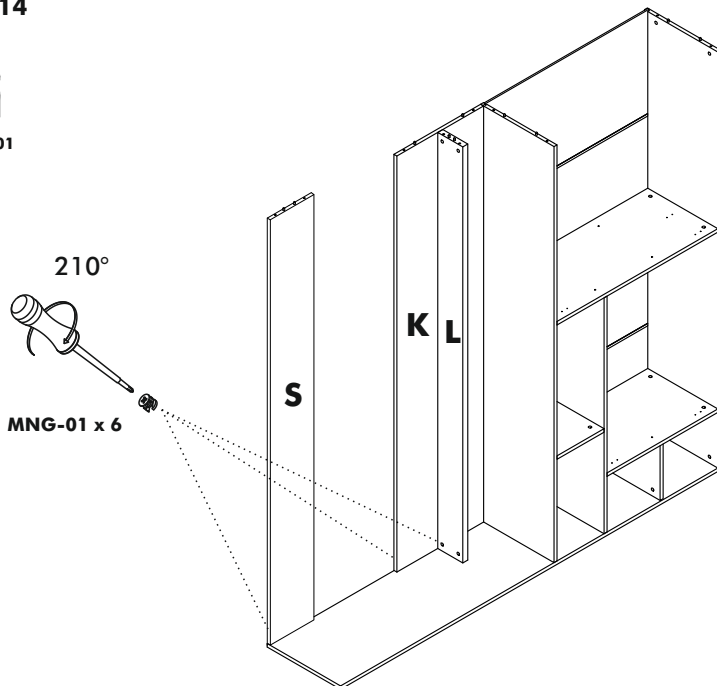

VIDEO

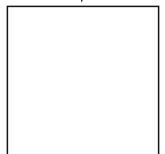

link

STEP 15



MNG - 01

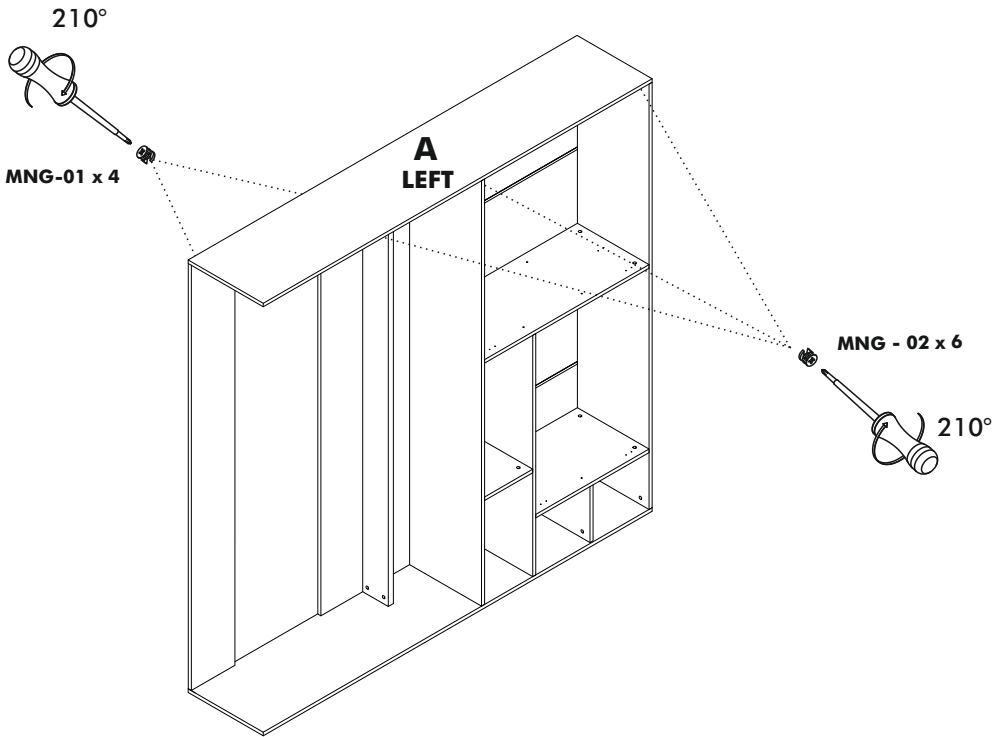

VIDEO

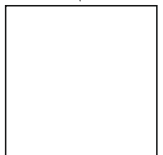

link

STEP 16

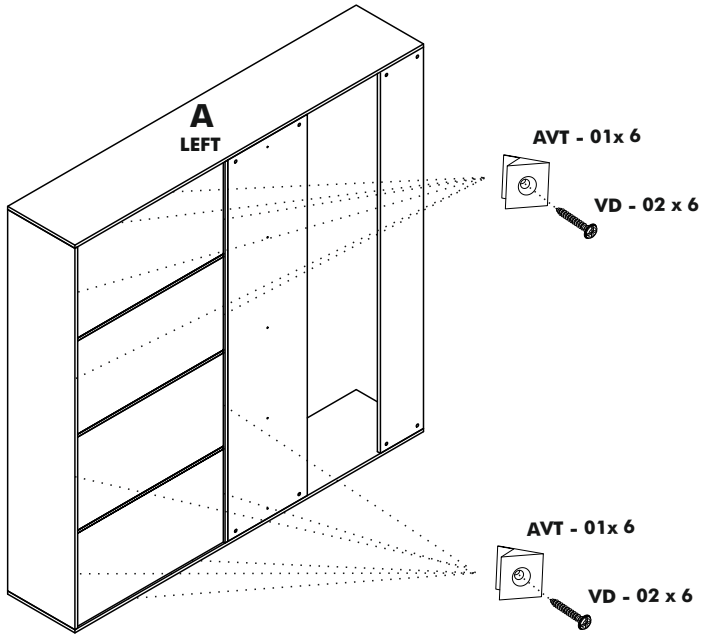

STEP 17

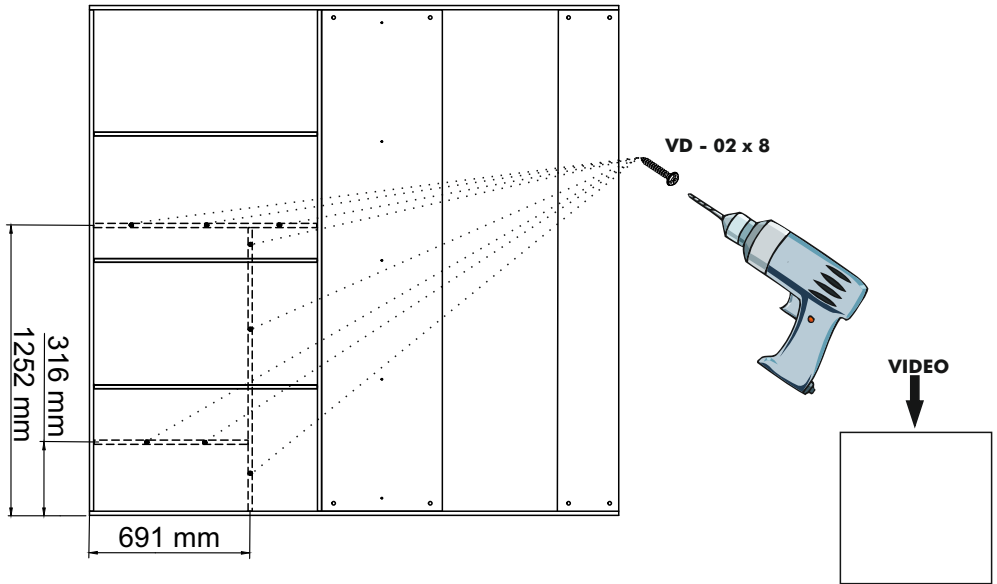

 **ATTENTION!!!**

STEP 18

Must be secured to the wall made of brick, concrete or similarly strong material.
Mounting to wooden or metal studs is also acceptable.
Do not mount directly to sheetrock or paper-mache type walls not supported by studs.

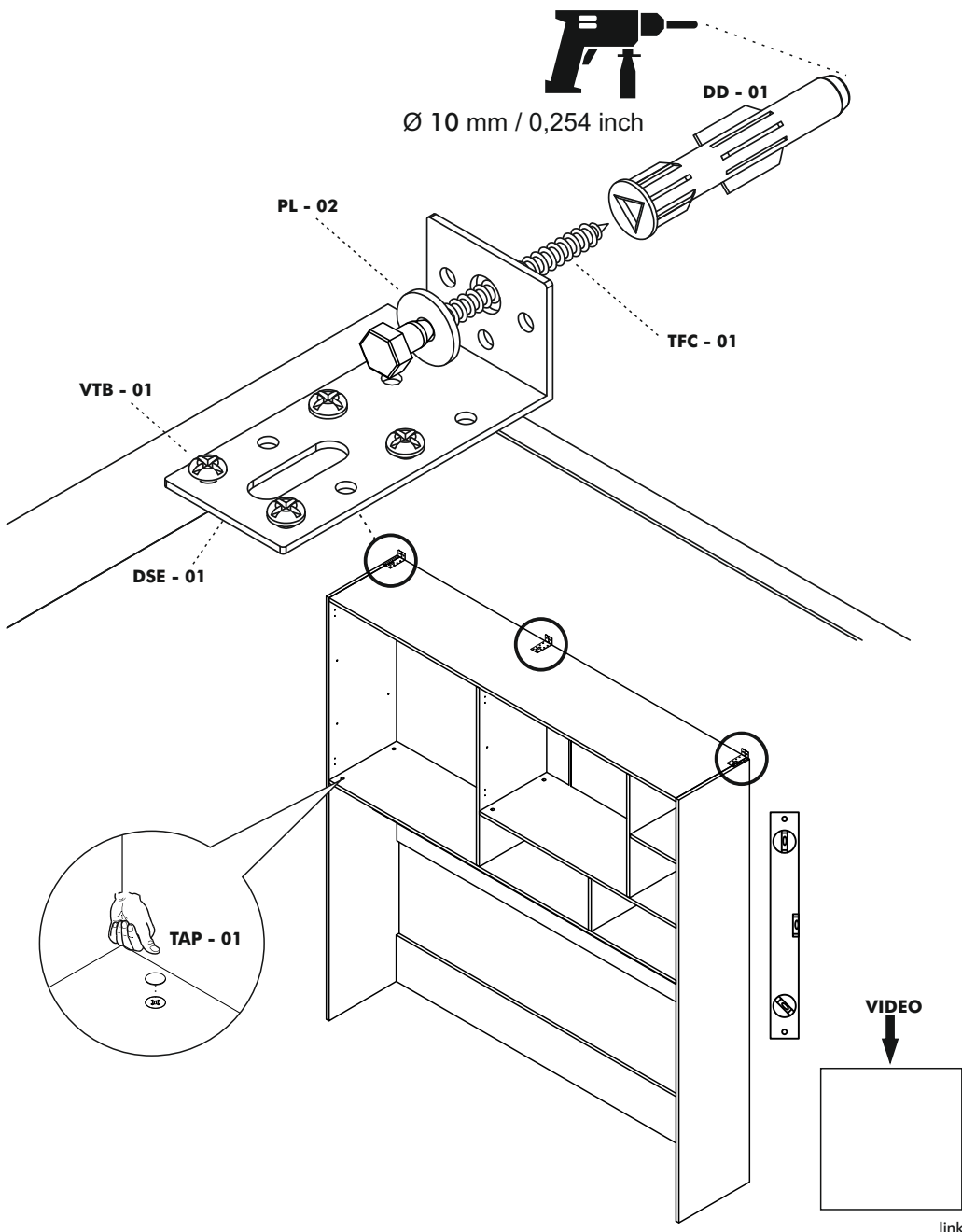

STEP 19

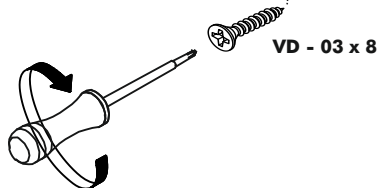
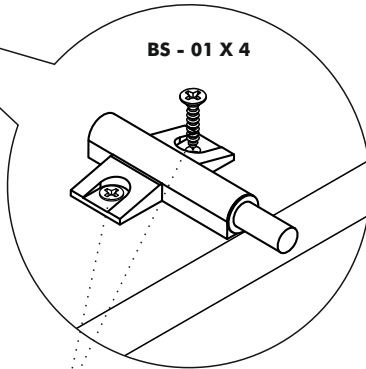
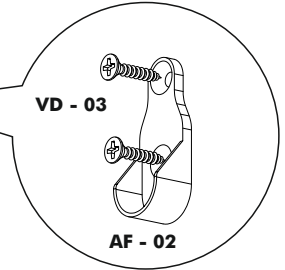
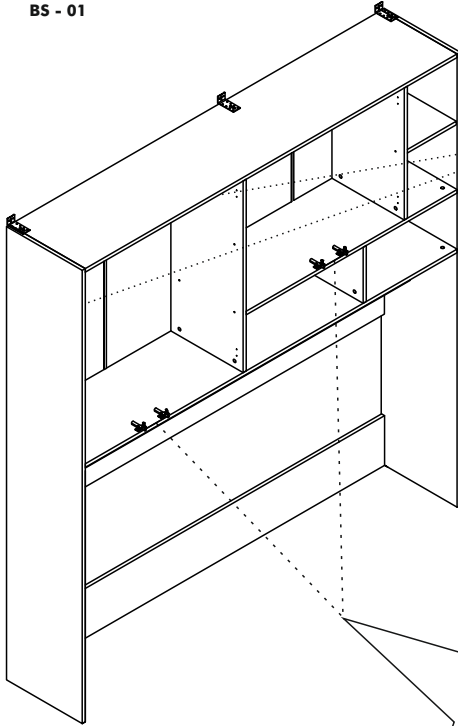
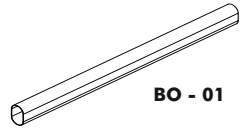
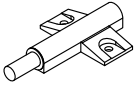

VIDEO

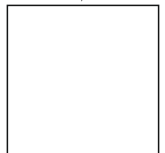

link

STEP 20

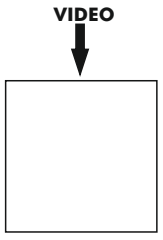
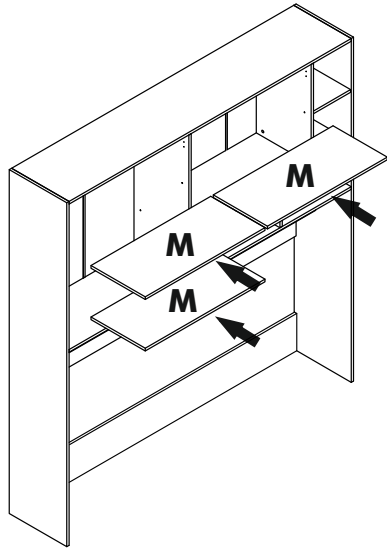
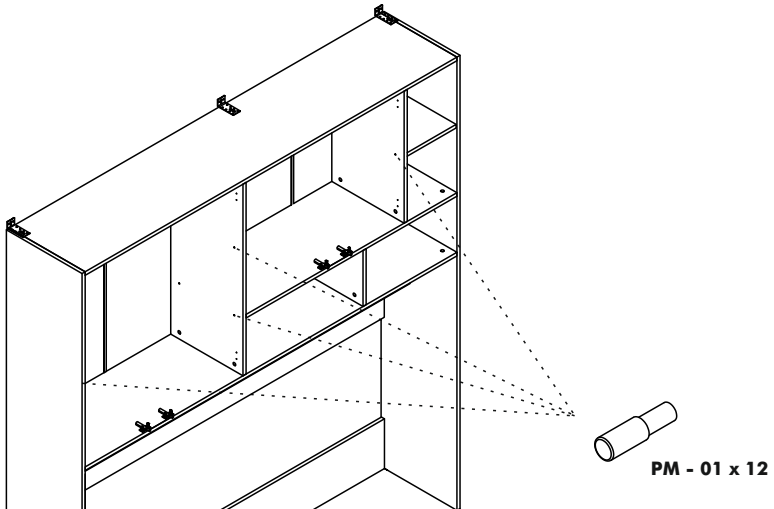

STEP 21

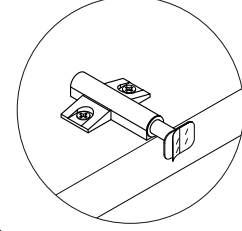
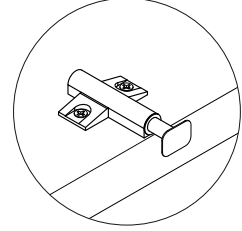
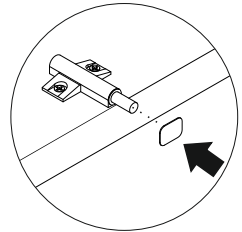
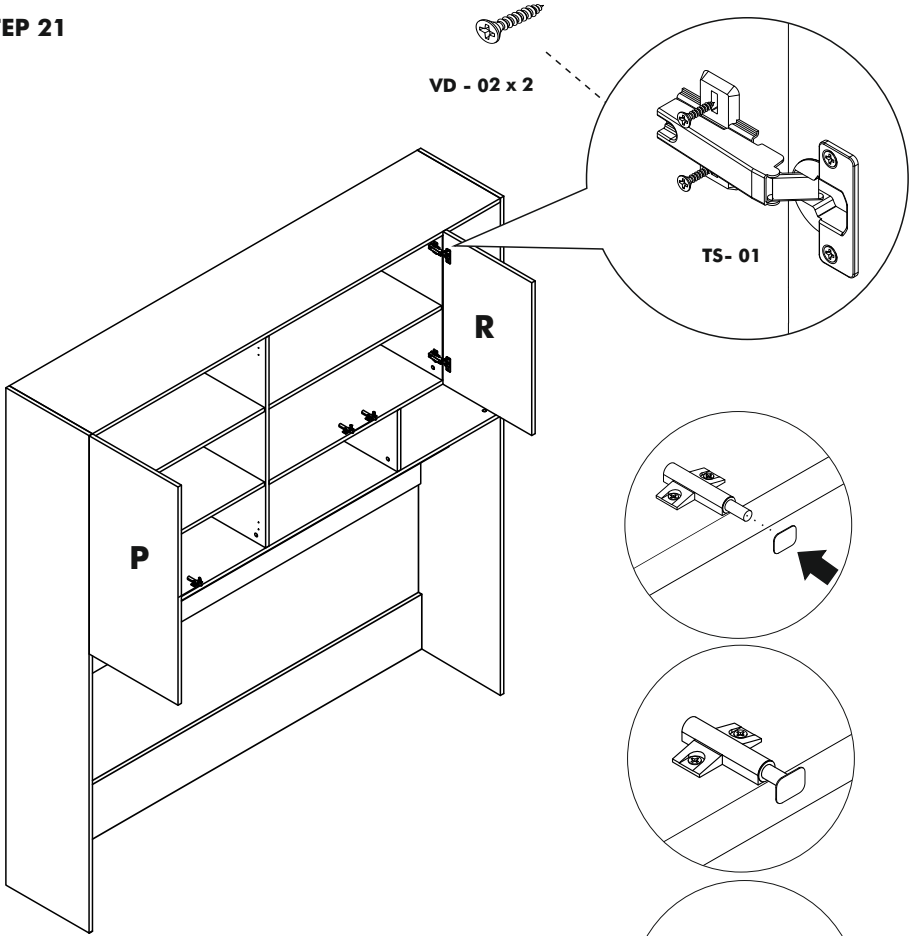

Yapıştırırmadan önce yüzeyin tozlu olmadığından emin olun.
Before sticking , make sure that the surface is not dusty.

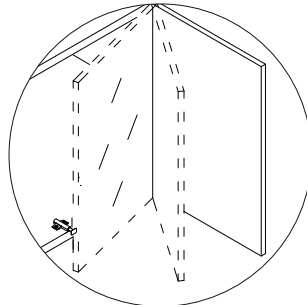

VIDEO

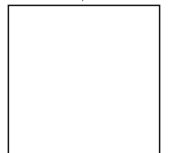

STEP 22

Yapıştırırmadan önce yüzeyin tozlu olmadığından emin olun.
Before sticking , make sure that the surface is not dusty.

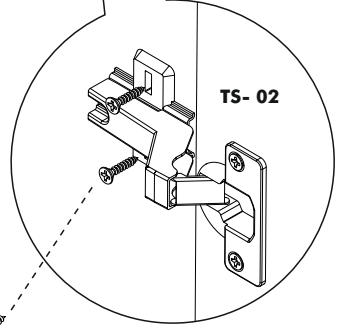
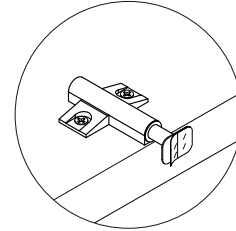
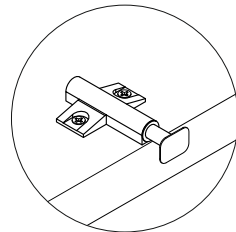
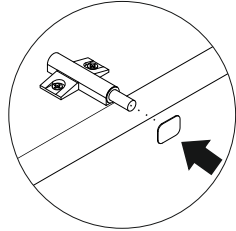
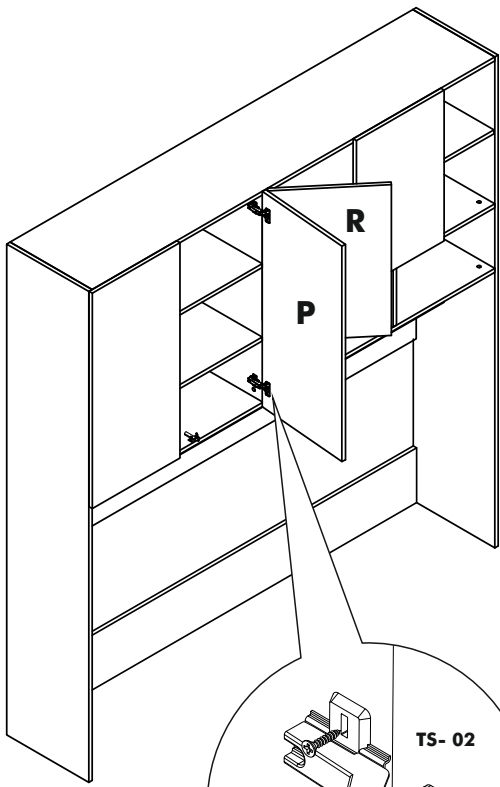

VD - 02 x 2

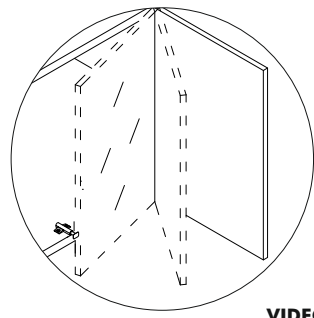

VIDEO

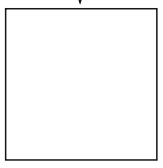

link

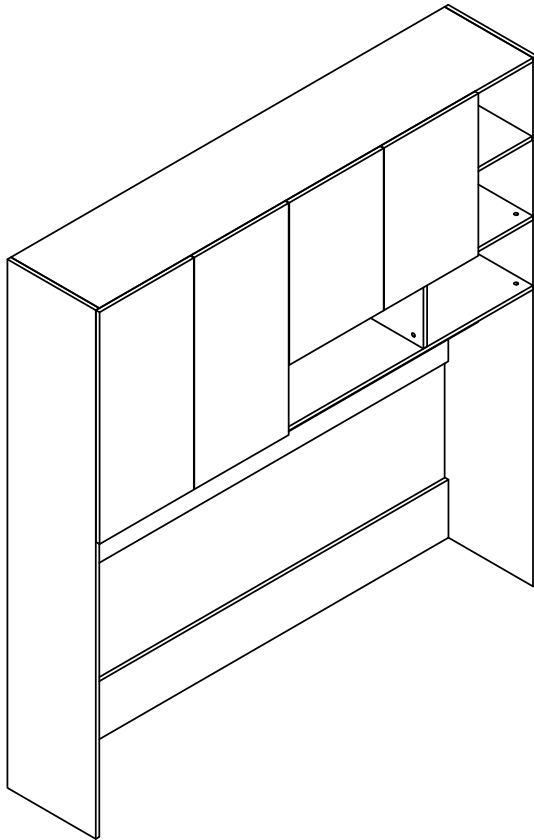

ATTENTION / HOW TO / READ ME / OWNER'S GUIDE

1. When mounting on a regular drywall, furniture must be fastened to wood or metal studs. Solid walls made of brick, concrete or similar strong material are also acceptable. Do not mount furniture to paper-mache or sheetrock (plasterboard) like material without properly fixing to stud.
2. For safety and product longevity you must periodically inspect the mounting and mechanical connections for integrity and tightness. Confirm hardware remains properly affixed and connections snug.
3. Wall Bed mattress thickness may not exceed 8 inches (200mm). Take care to remove pillows and excess blankets before closing. Doing so keeps mechanism free of obstruction and unnecessary stress.
4. Do not lean or rest heavy objects on side or top of furniture. This may cause balance issues and compromise the integrity of your mounting connections.
5. Please use the furniture's beds, desks and shelving as intended. Not designed to be sat, stood, leaned, jumped (etc) on. Improper use may cause personal injury and damage to property.
6. With seasonal humidity change you must inspect interior and exterior of furniture.
7. Single bed models are suitable for the weight of one person. Sleeping by more than one person will cause damage of the product.
8. Before any un-mounting or disassembly please contact Multimo for technical support and instruction. Failure to properly detach risks injury to person and damage to property.
9. For Bunk Beds:
 - a. Always use provided ladder when accessing top bunk.
 - b. Be slow, careful and aware of surroundings when opening top bunk.
 - c. Do not horseplay. Beds are to be slept on only.
 - d. Some have legs that fully extend when open- be aware of where the leg is and will be.



MULTiMO

www.multimo.com