

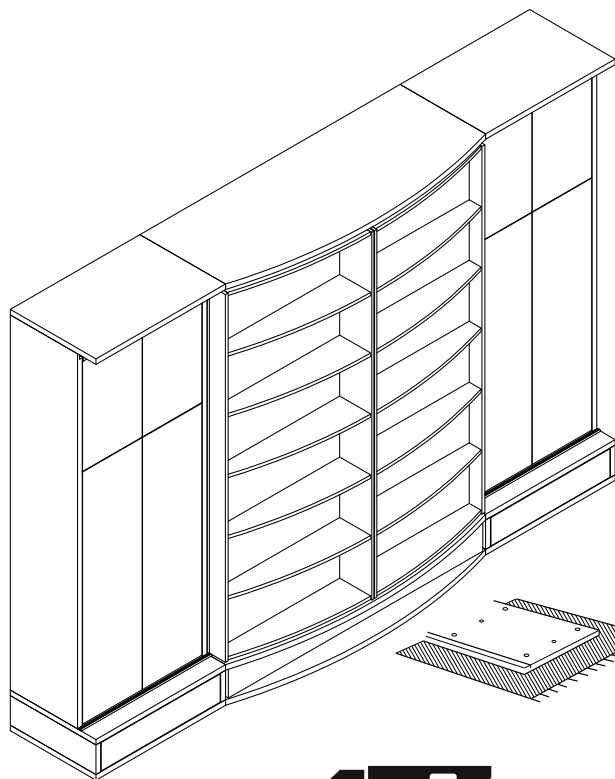

# MULTIMO

## 151- SUIT BED



**110** min.



Technical Service



**130** min.



End User

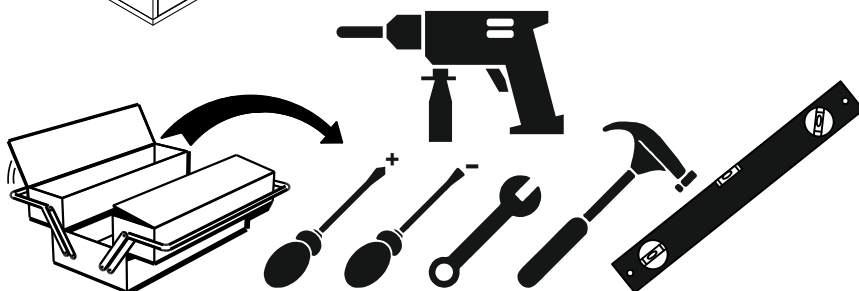
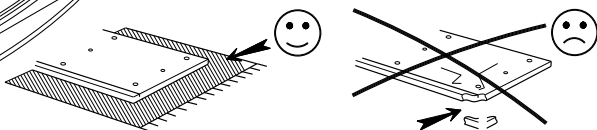



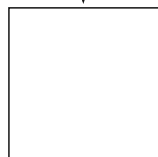



VIDEO

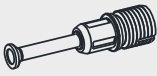

link

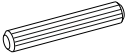
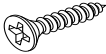
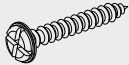
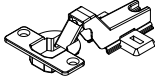
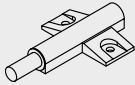
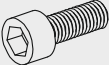
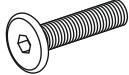
Track Title	Piece	(inch)			(mm)			
		Thickness	Length	Width	Piece	Thick	Height	Most
<b>A</b>	1	1,18	58,90	25,79	1	30	1496	655
<b>B</b>	1	1,18	58,90	9,25	1	30	1496	235
<b>C</b>	1	1,18	58,90	25,79	1	30	1496	655
<b>D</b>	2	0,71	57,48	4,72	2	18	1460	120
<b>E</b>	2	1,18	57,48	3,94	2	30	1460	100
<b>F</b>	2	0,71	87,40	16,54	2	18	2220	420
<b>G</b>	1	0,71	58,90	6,30	1	18	1496	160
<b>H</b>	2	0,71	6,30	3,78	2	18	160	96
<b>K</b>	2	8,66	78,35	29,33	2	220	1990	745
<b>L</b>	4	1,18	79,92	16,54	4	30	2030	420
<b>M</b>	2	8,66	29,53	21,06	2	220	750	535
<b>N</b>	2	1,18	29,53	21,06	2	30	750	535
<b>O</b>	2	0,71	27,09	14,96	2	18	688	380
<b>P</b>	2	0,71	27,09	14,17	2	18	688	360
<b>R</b>	4	0,71	53,70	13,46	4	18	1364	342
<b>S</b>	4	0,71	24,72	13,46	4	18	628	342
<b>U</b>	2	0,31	80,59	27,80	2	8	2047	706
<b>Y</b>	3	0,31	88,03	19,33	3	8	2236	491

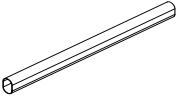
### Accessories List

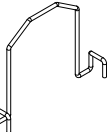
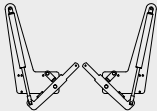
<b>MX 02</b>  <b>60 / piece</b> <b>VD - 03 ( 3,5x18 ) mm</b>	<b>MNG - 01</b>  <b>60/ piece</b> <b>VD - 02 (3,5x25) mm</b>	<b>TAP - 01</b>  <b>60 / piece</b> <b>TS - 03</b>	<b>KVL 01</b>  <b>64 / piece</b> <b>B5 - 01</b>
 <b>122 / piece</b> <b>IM - 02 (6x20) mm</b>	 <b>18 / piece</b> <b>CT - 03 ( 6x50 ) mm</b>	 <b>20 / piece</b> <b>PM - 01</b>	 <b>8 / piece</b> <b>H 01</b>
 <b>4 / piece</b> <b>BO - 01</b>	 <b>8 / piece</b> <b>AF - 01</b>	 <b>8 / piece</b> <b>TTC 01</b>	 <b>2 / piece</b> <b>MKZ - 02</b>
 <b>2 / piece</b>	 <b>4 / piece</b>	 <b>6 / piece</b>	 <b>1 / piece</b> <b>700 N</b>

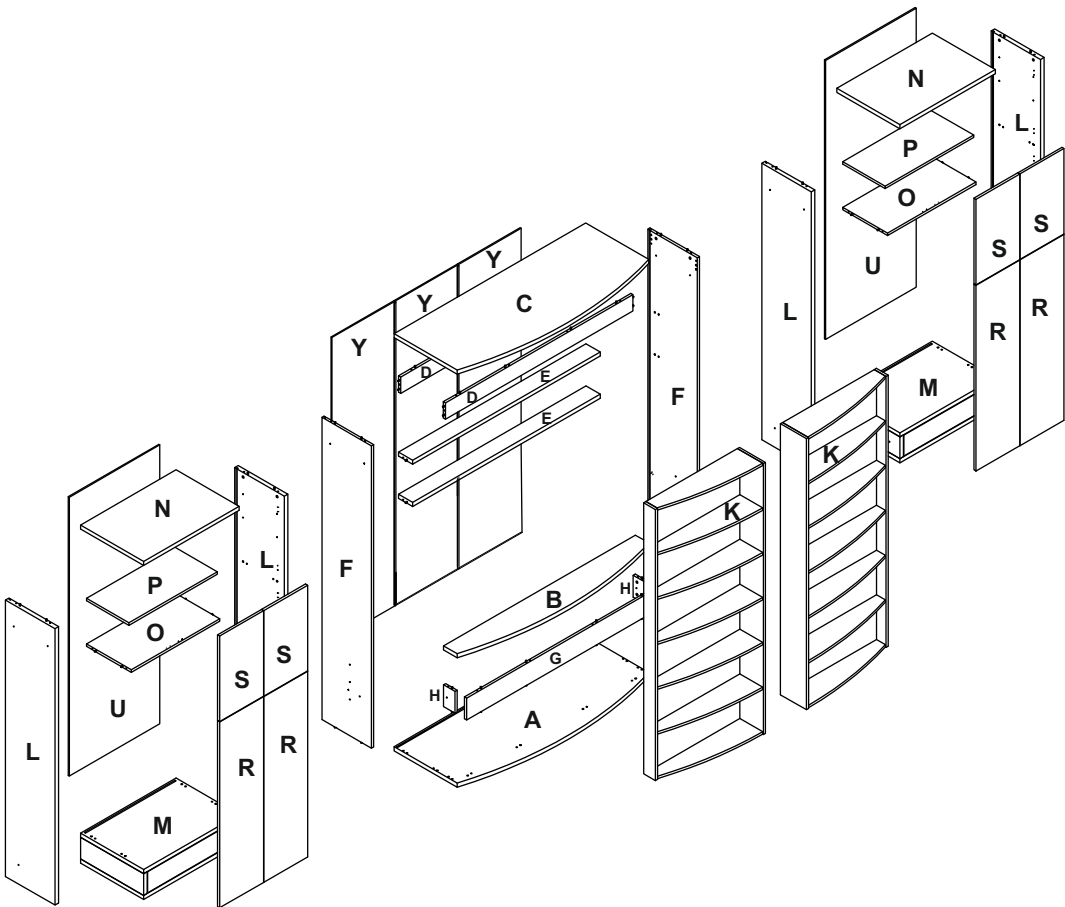

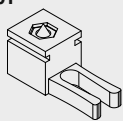
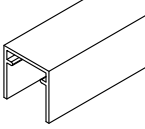
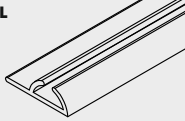
<p><b>STP - 01</b></p>  <p><b>4 / piece</b></p>	<p><b>AL-80</b></p>  <p><b>2 / piece</b></p>	<p><b>AL 91-L</b></p>  <p><b>2 / piece</b></p>
--	---	---

**STEP 1**



MNX - 02

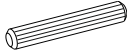

KVL 01

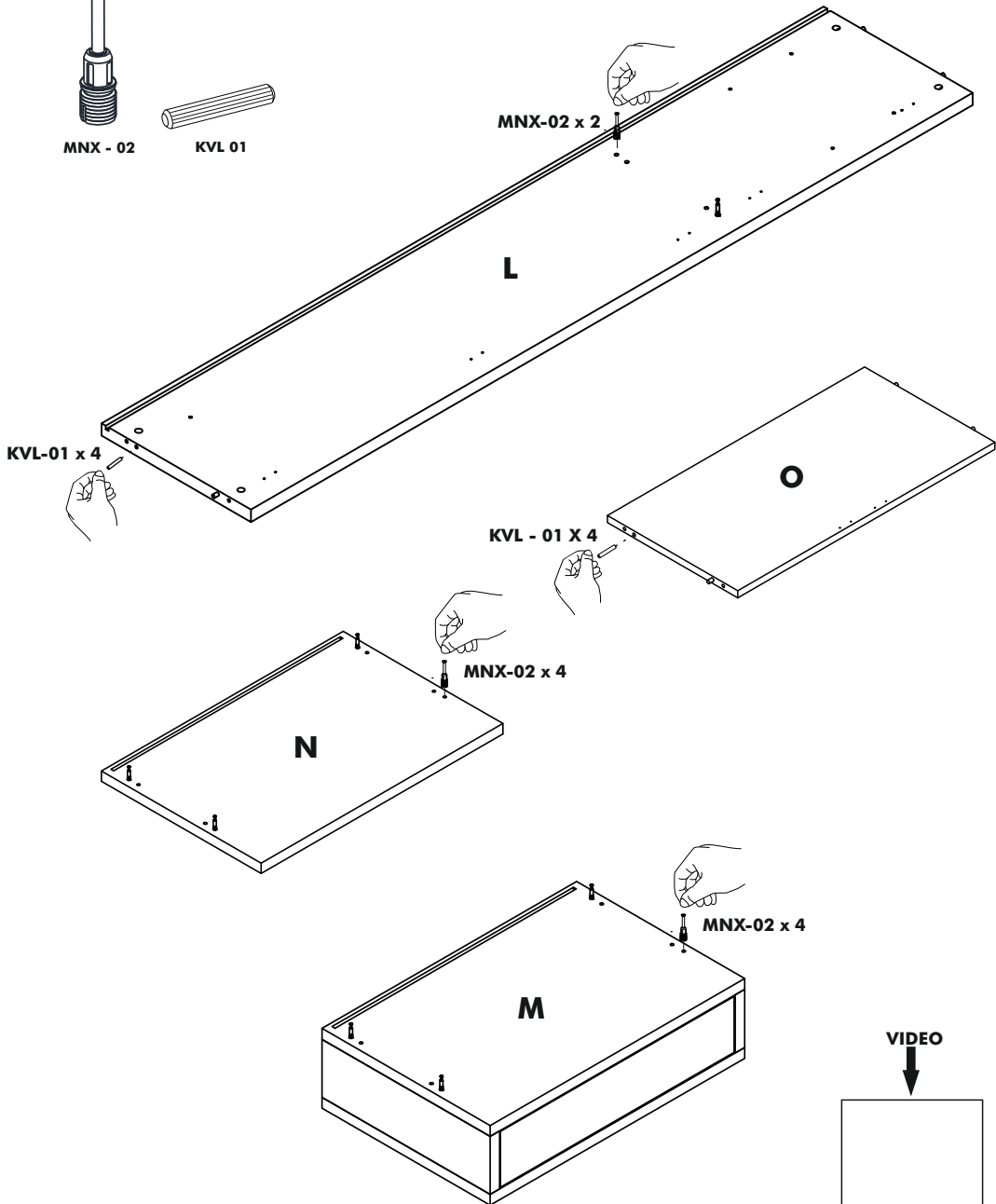

**VIDEO**

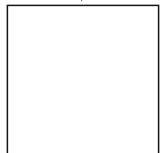

link

**STEP 2**

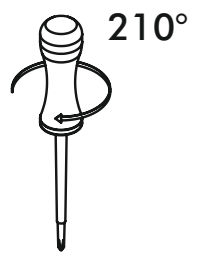
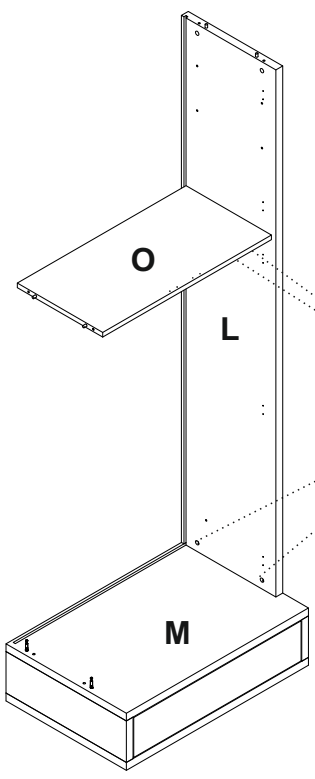

**STEP 3**

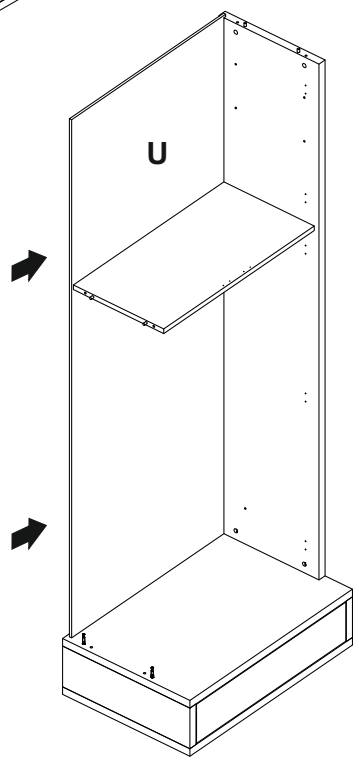

**VIDEO**

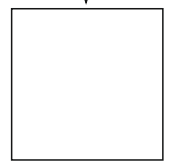

link

**STEP 4**

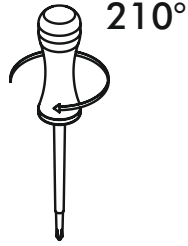
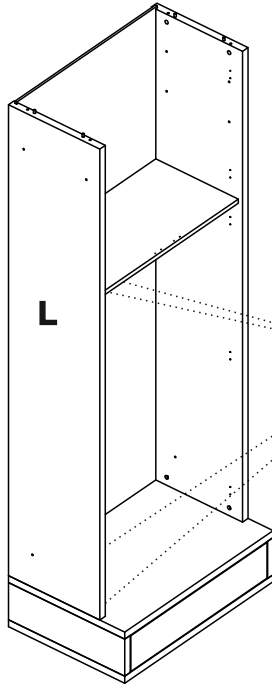

**STEP 5**

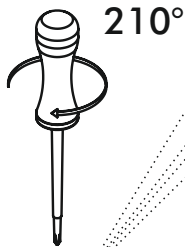

MNG - 01 x 4

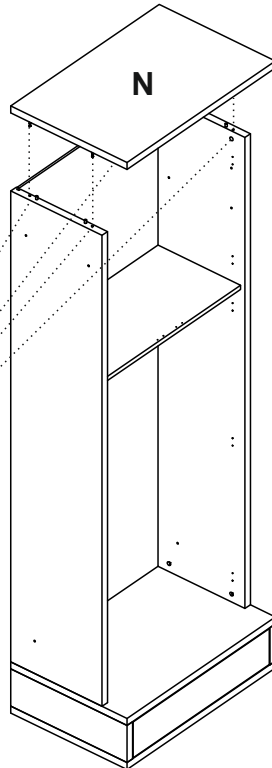

**VIDEO**

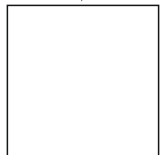

link

**STEP 6**

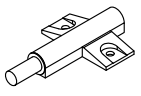

**BS - 01**

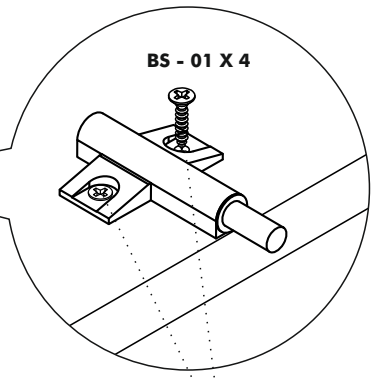
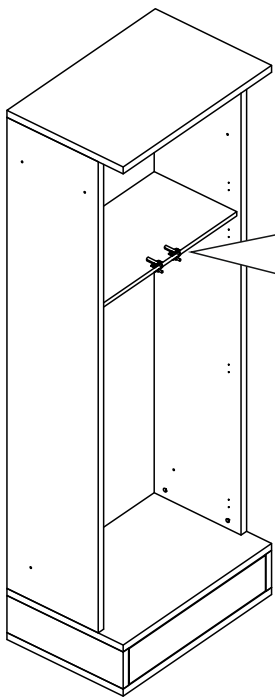

**BS - 01 X 4**

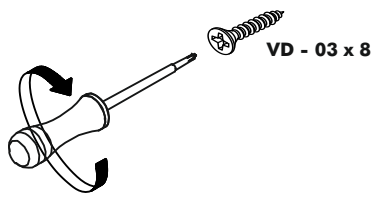

**VD - 03 x 8**

**STEP 7**

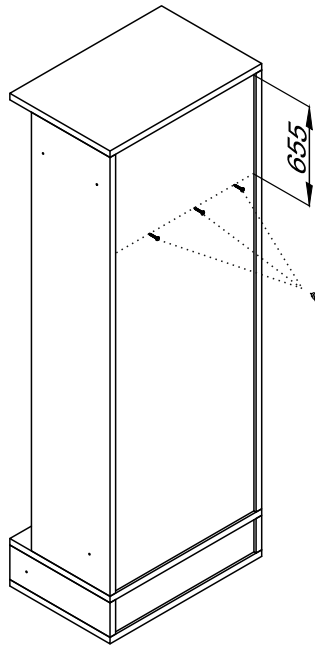

655

**VD - 02 x 3**



**VIDEO**

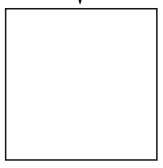

link

**STEP 8**



MNX - 02

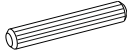

KVL 01

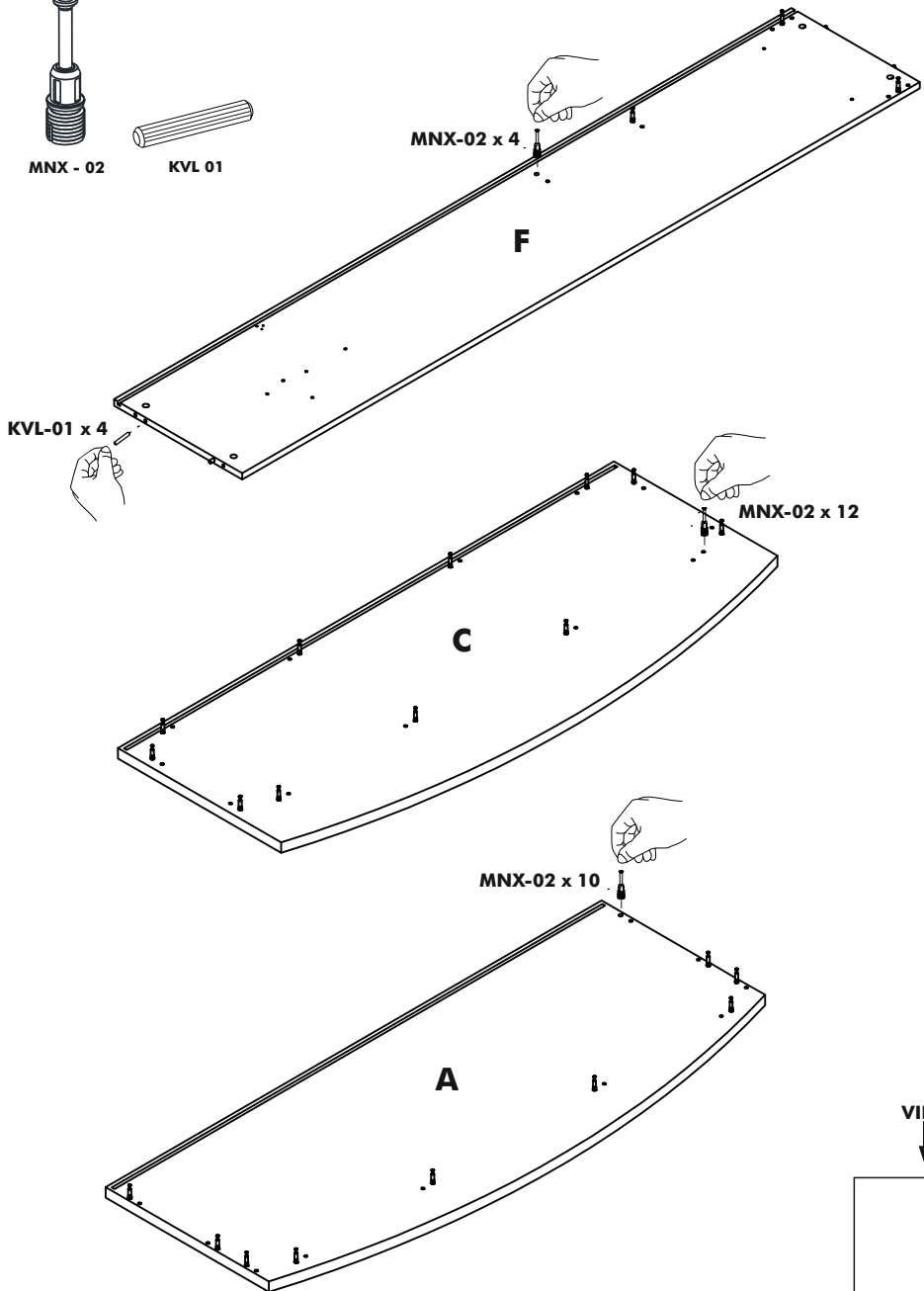

**VIDEO**

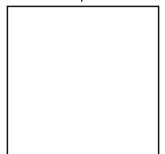

link



**STEP 9**

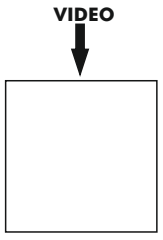
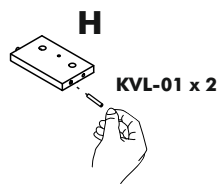
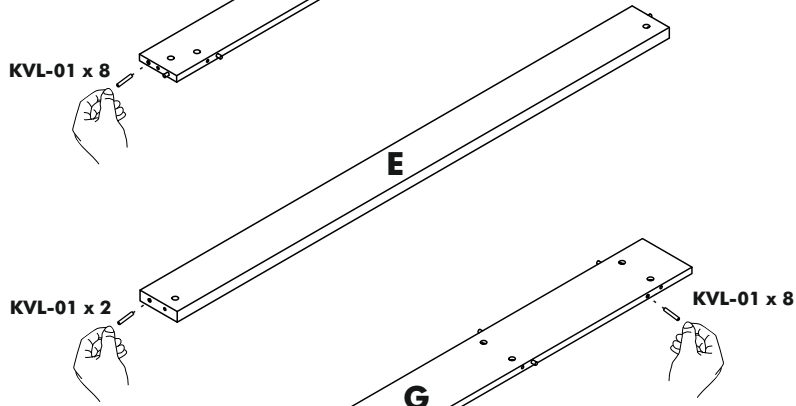
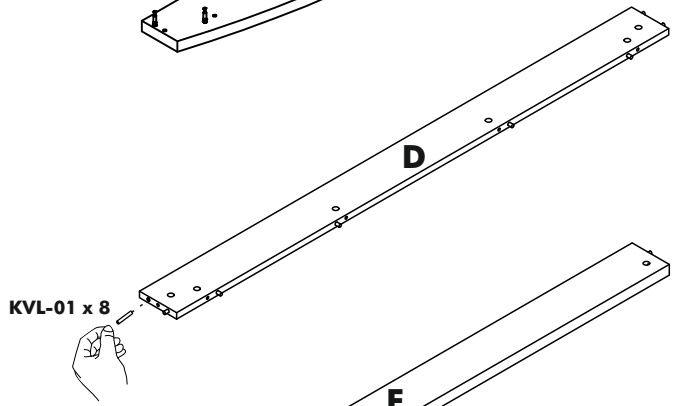
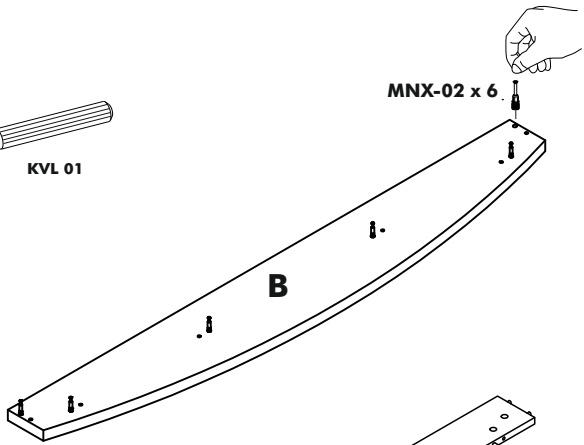
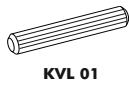

STEP 10

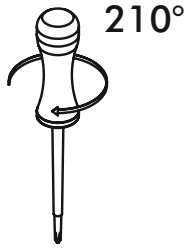

MNG - 01 x 6

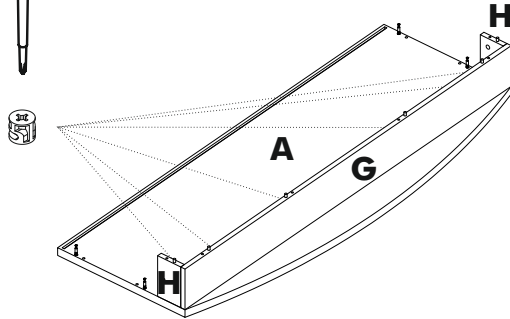

STEP 11

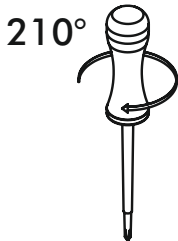

MNG - 01 x 6

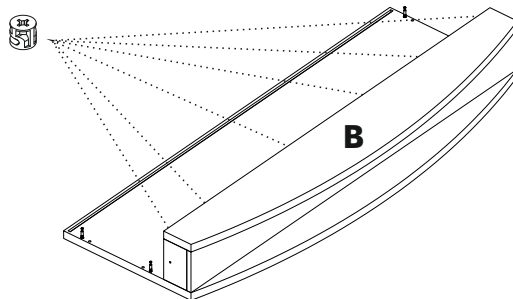
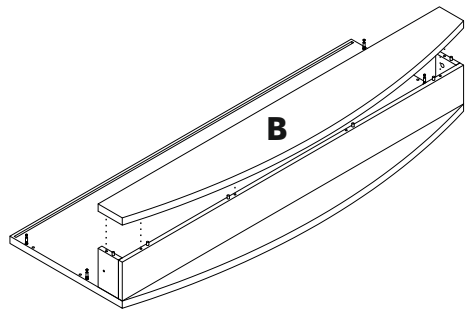

VIDEO

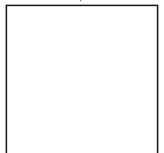

link

**STEP 12**

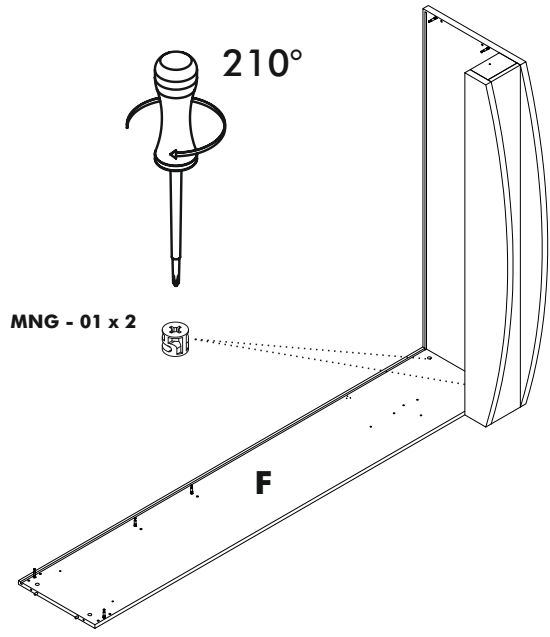

**STEP 13**

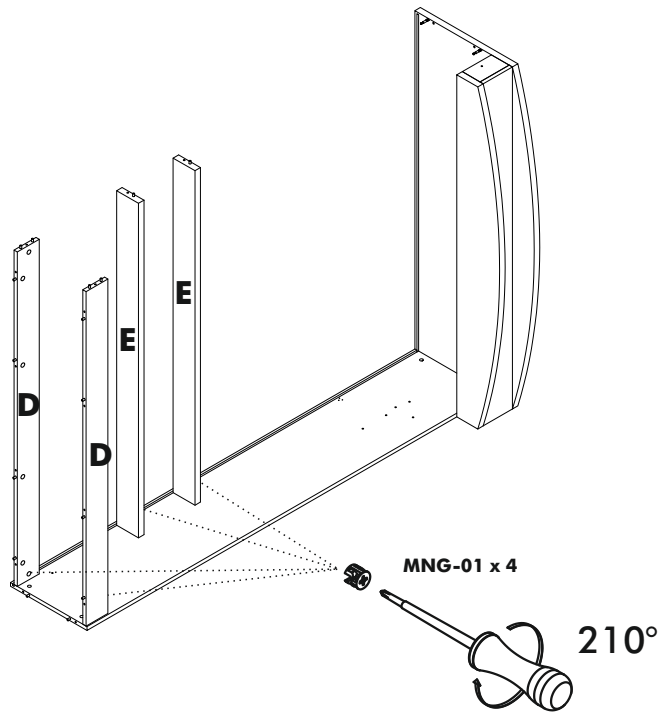

**VIDEO**

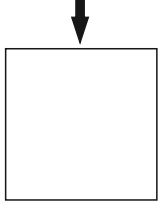

link

**STEP 14**

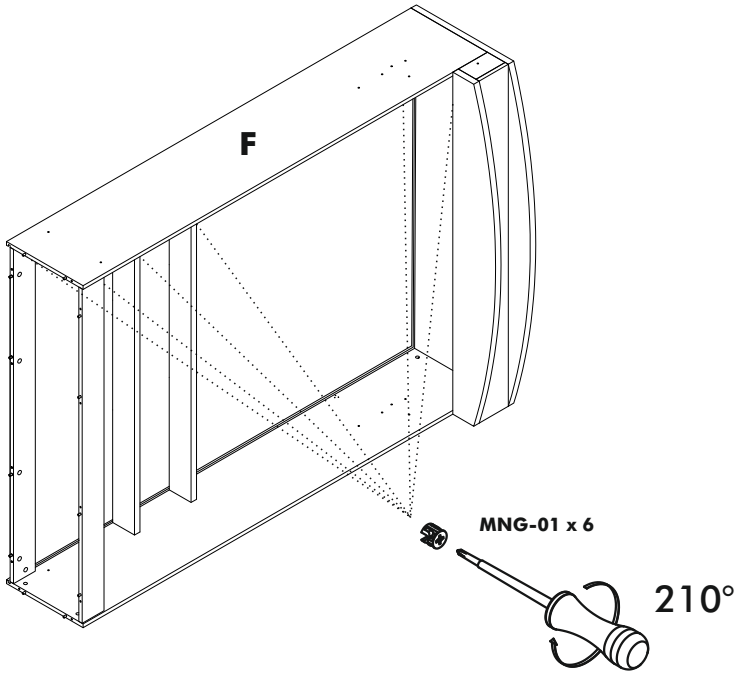

**STEP 15**

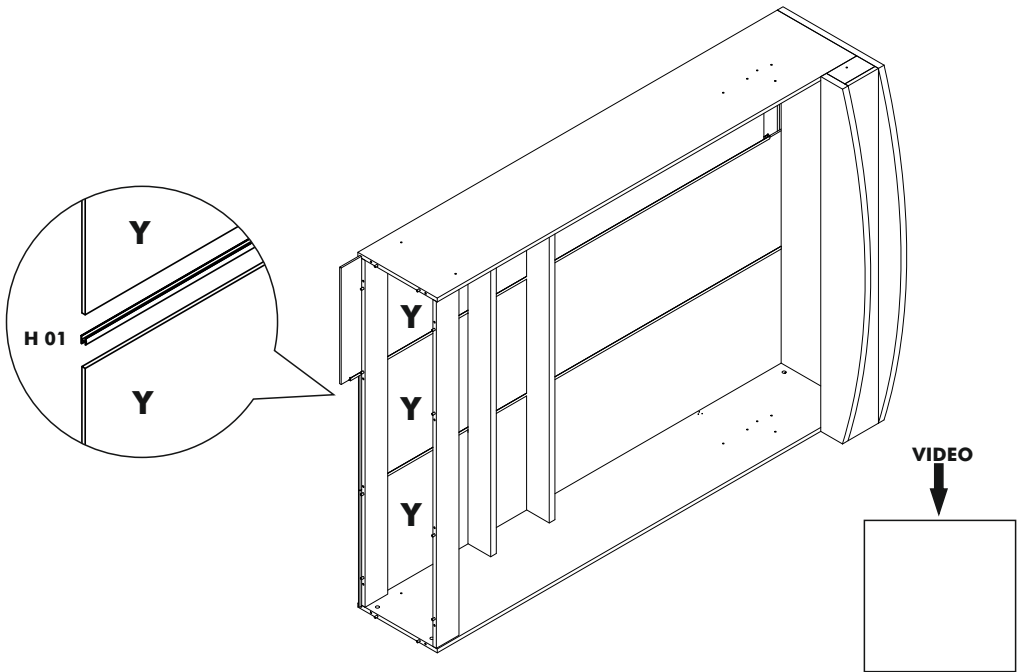

**STEP 16**

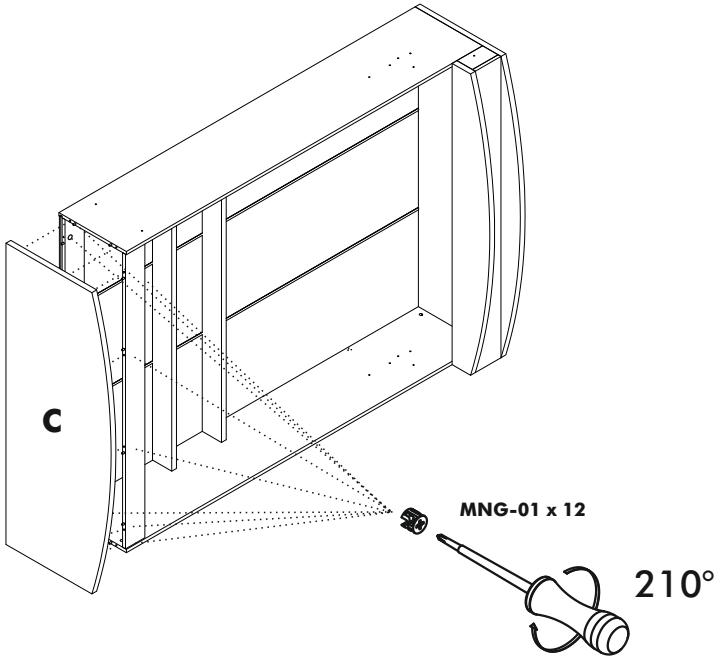

**STEP 17**

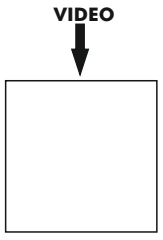
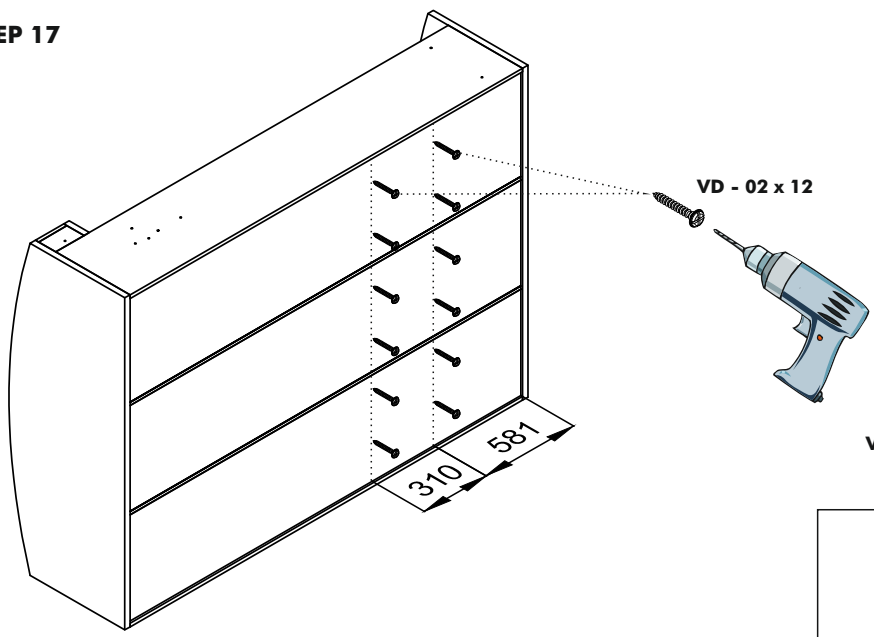

STEP 18

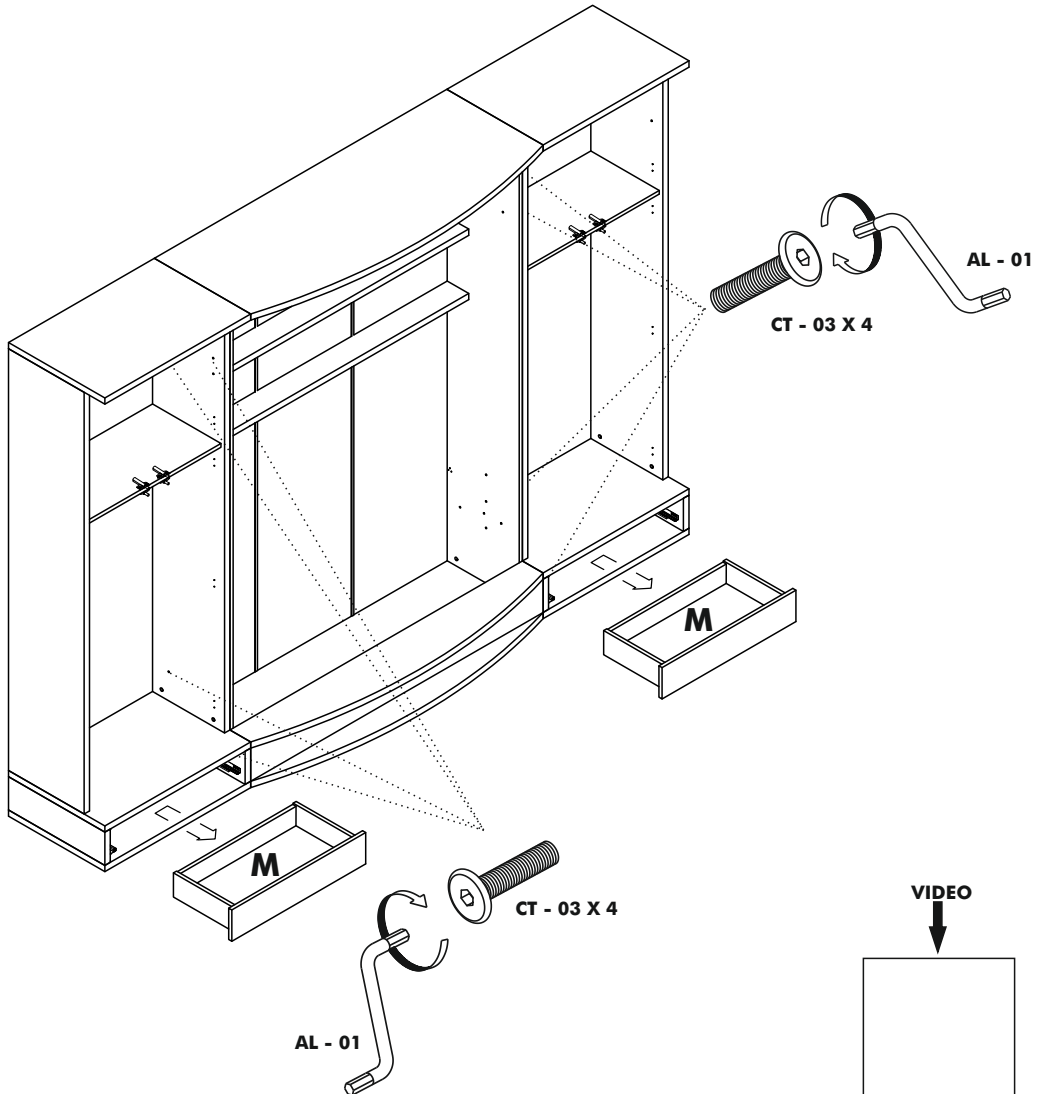
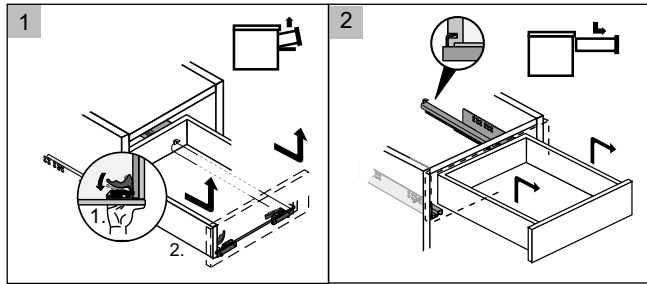

VIDEO

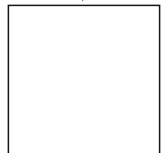

link

# STEP 19

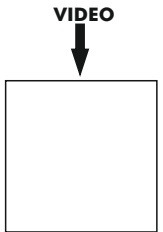
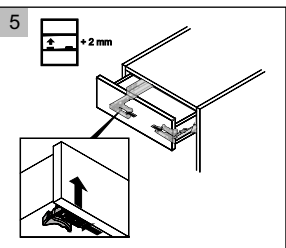
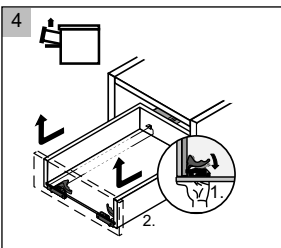
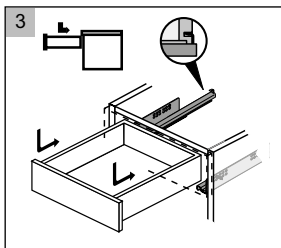
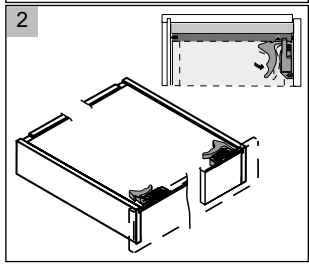
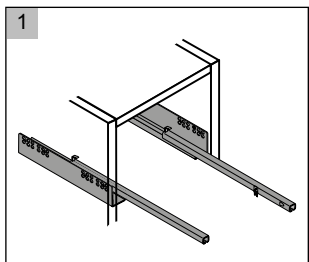
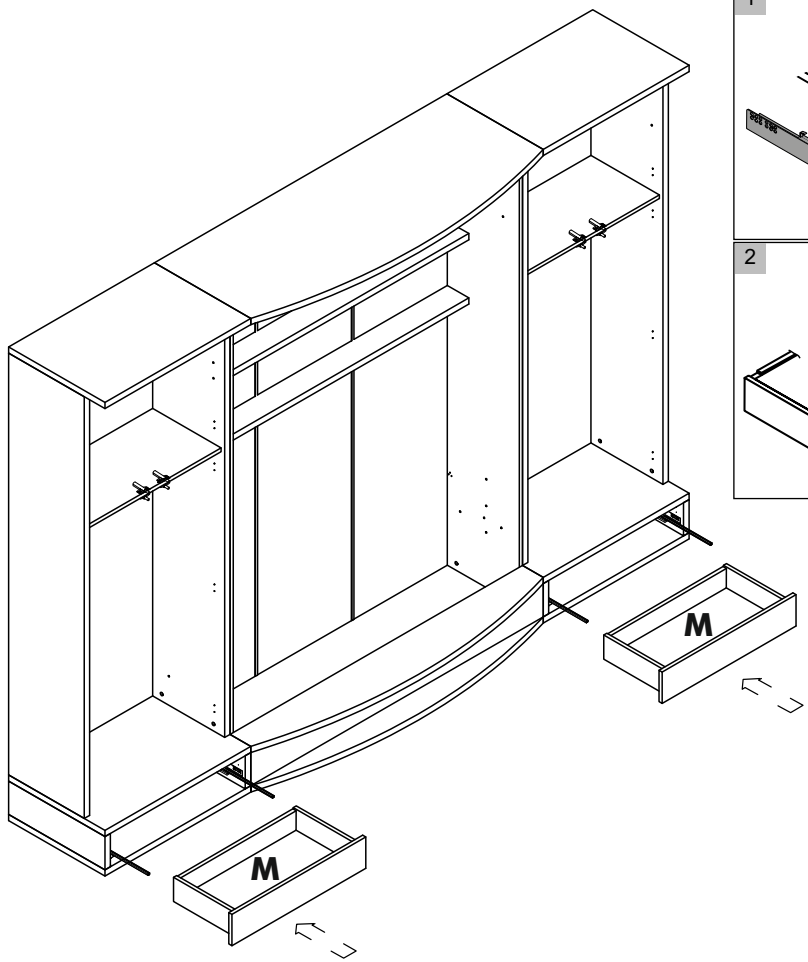

STEP 20

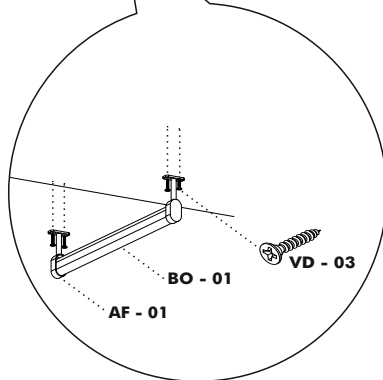
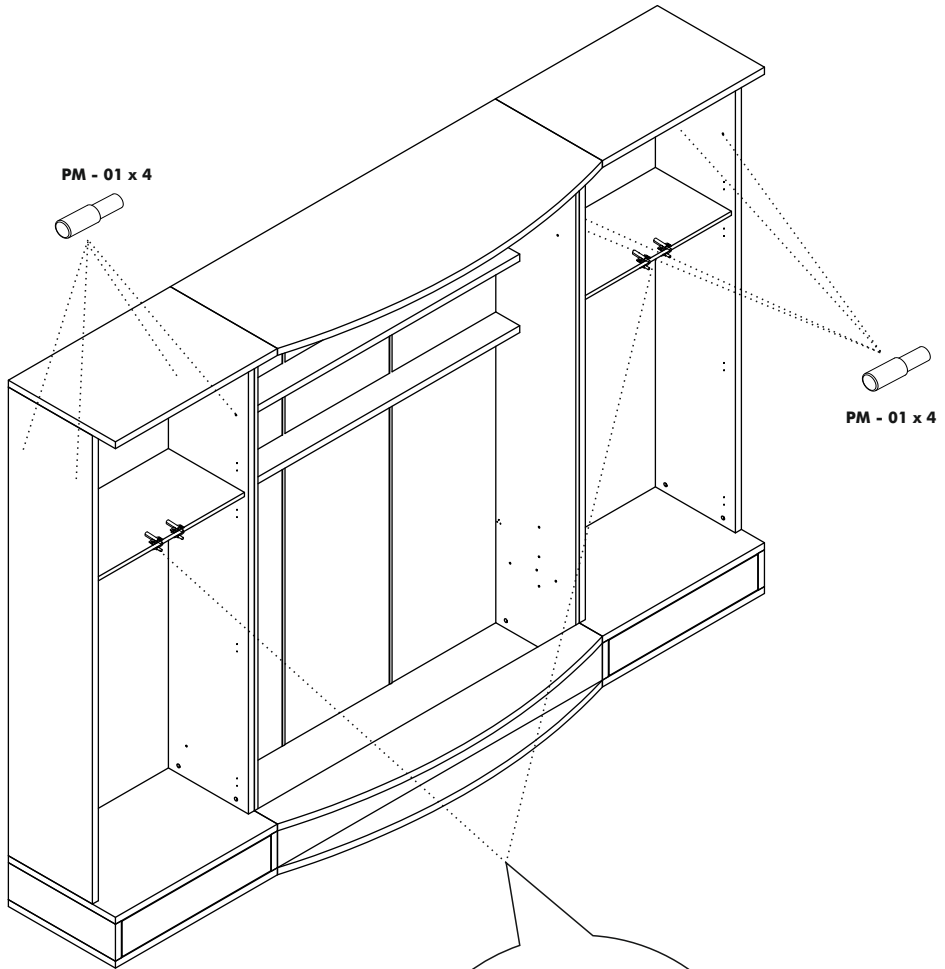

VIDEO

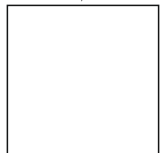

link



**STEP 21**

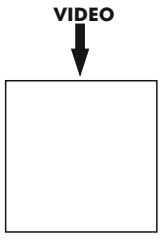
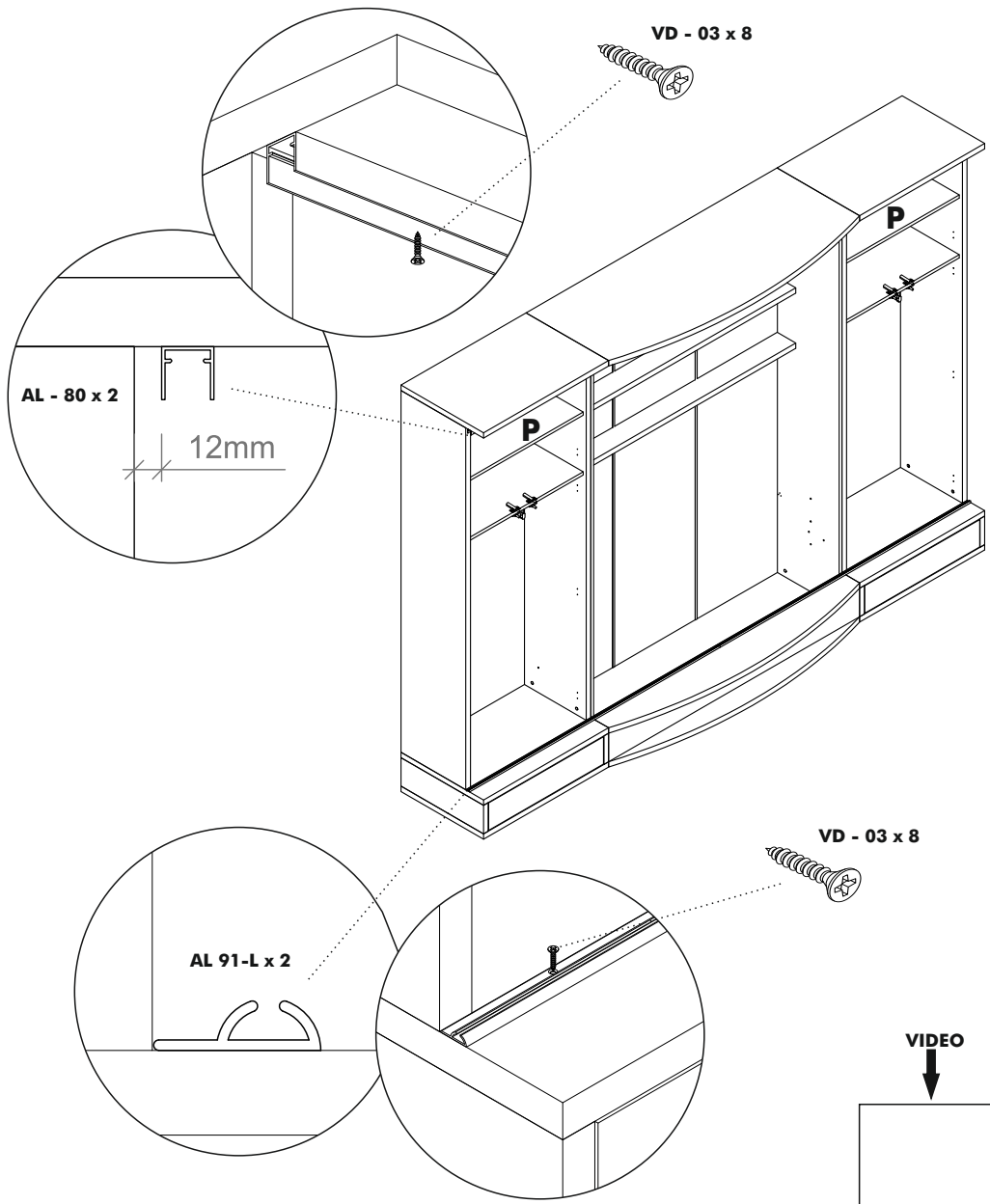

**STEP 22**

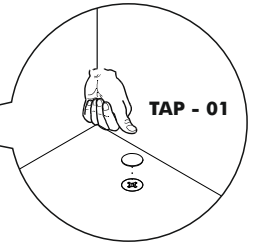
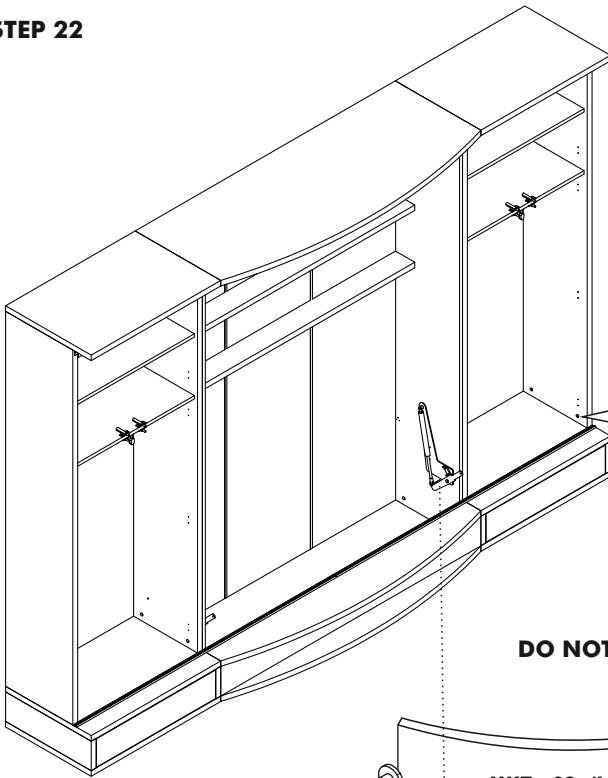

**CAUTION**  
**DO NOT UNLOCK BEFORE INSTALL**

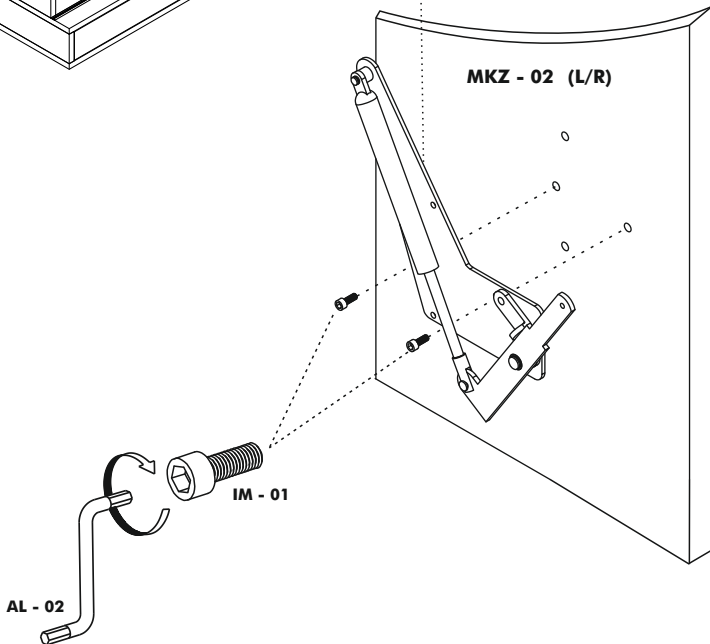

**VIDEO**

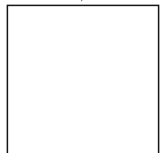

link

**STEP 23**

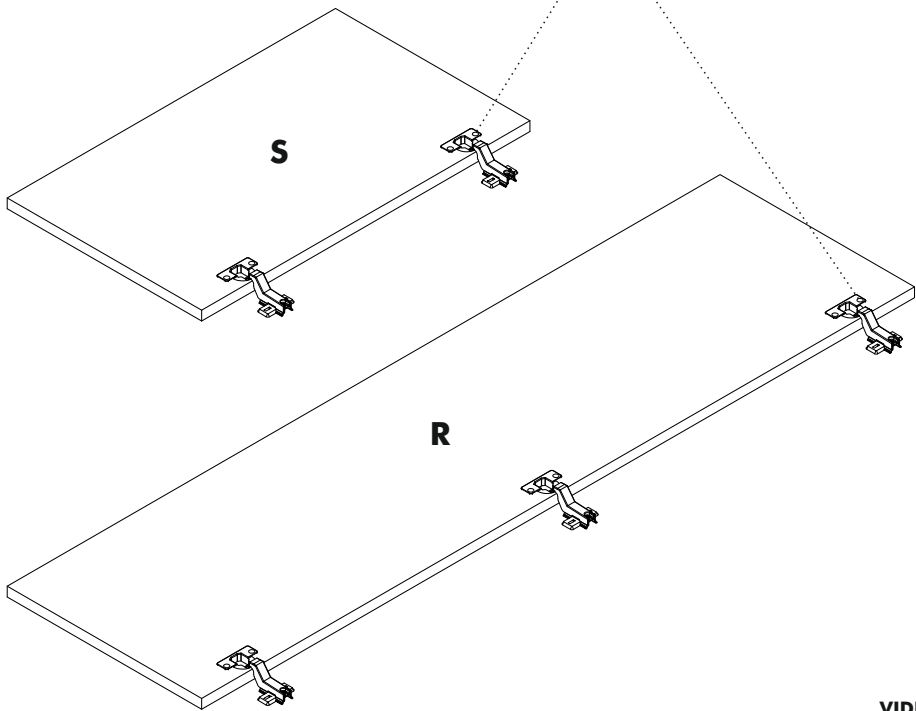
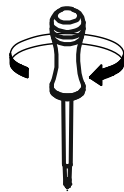
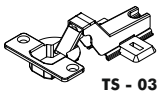

**VIDEO**

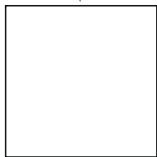

link

**STEP 24**

Yapıştırılmadan önce yüzeyin tozlu olmadığından emin olun.  
Before sticking , make sure that the surface is not dusty.

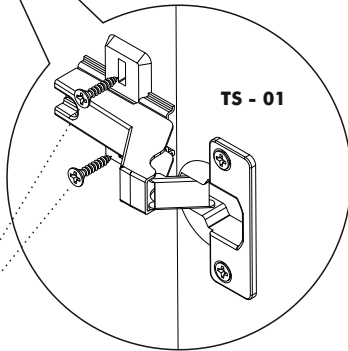
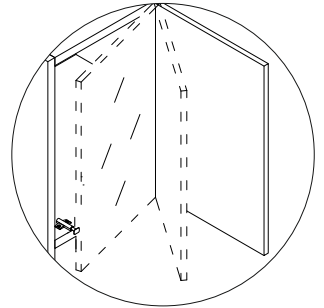
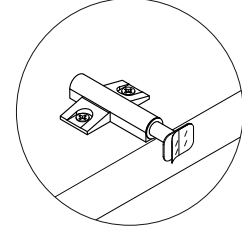
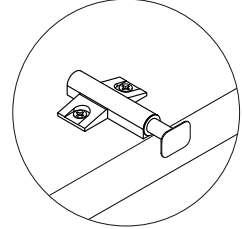
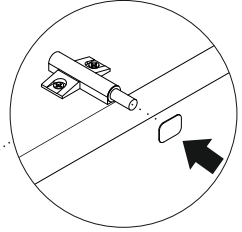
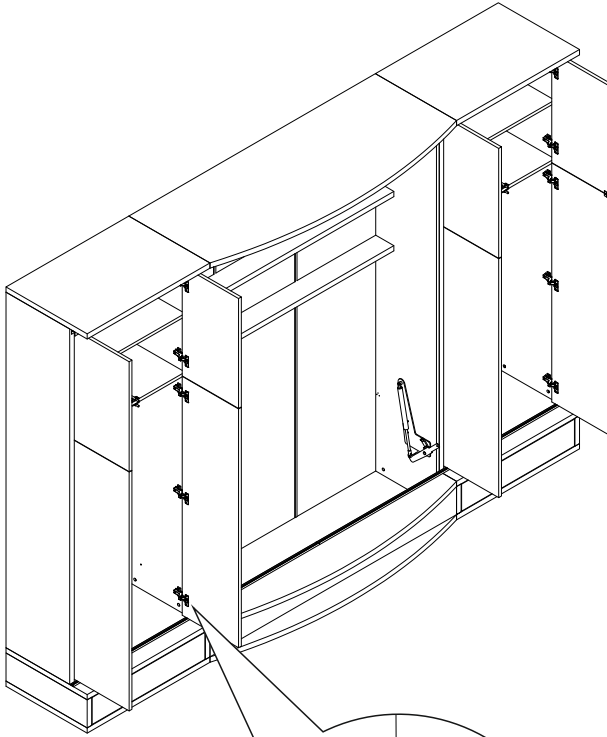

VD - 03 x 2

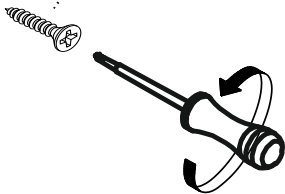

**VIDEO**

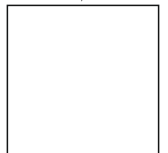

link

**STEP 25**

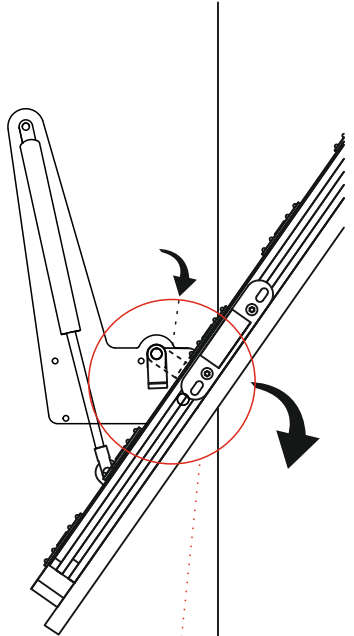
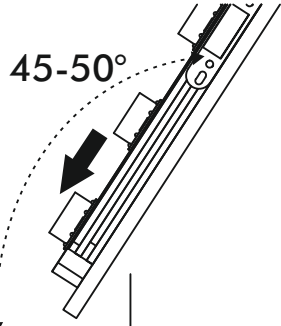
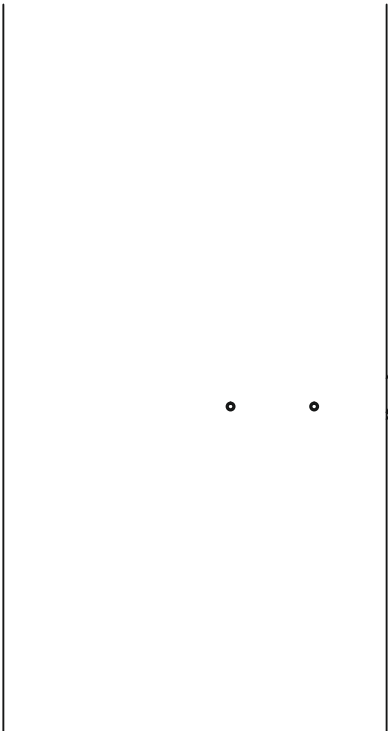

**KAPAK KAPATILMADAN KİLİDİ İNDİRİN !!!  
LET THE STOPPER LOCK MOVE DOWN !!!**

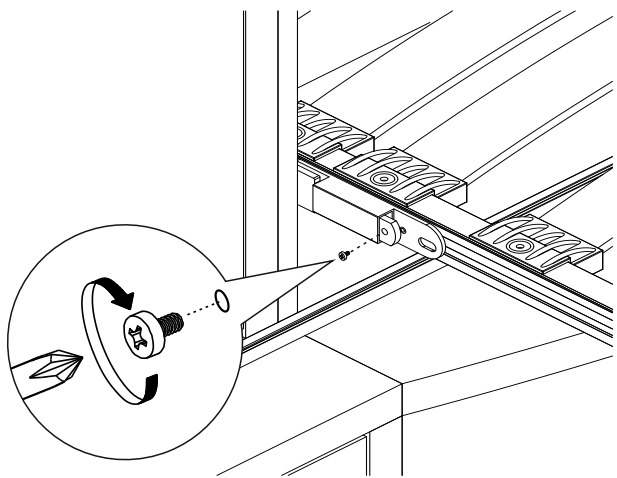
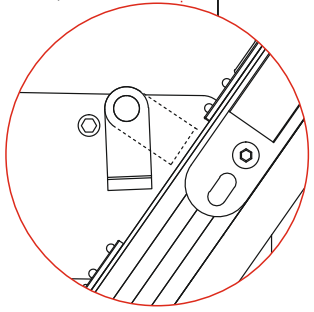

**VIDEO**

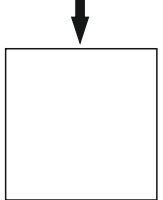

link

STEP 26

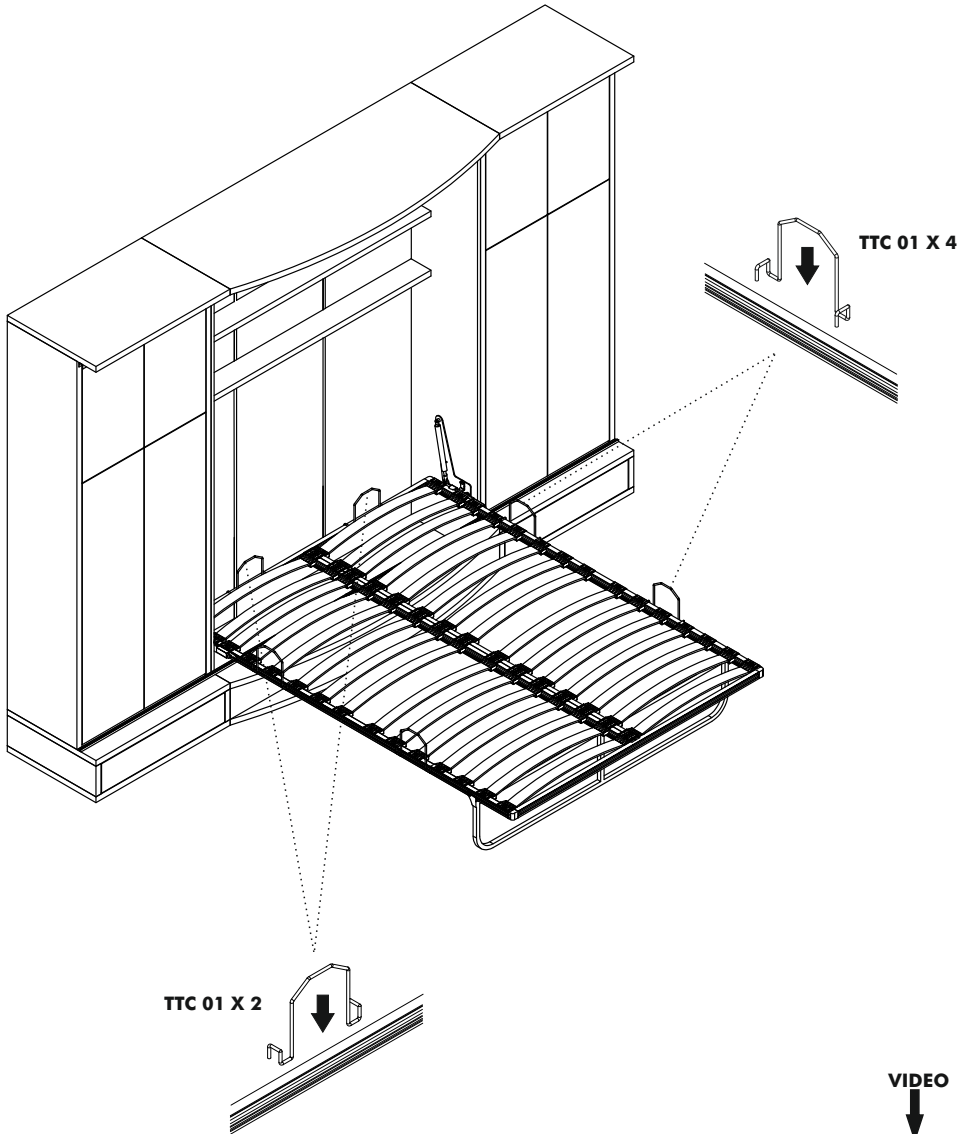

VIDEO

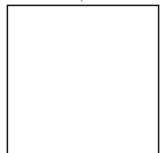

link

**STEP 27**

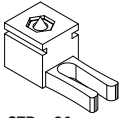

**SPT - 01**

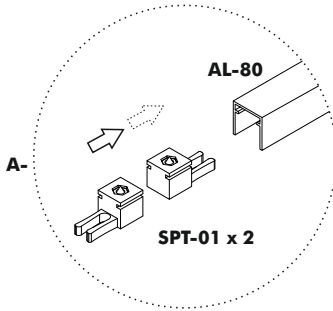

**AL-80**

**SPT-01 x 2**

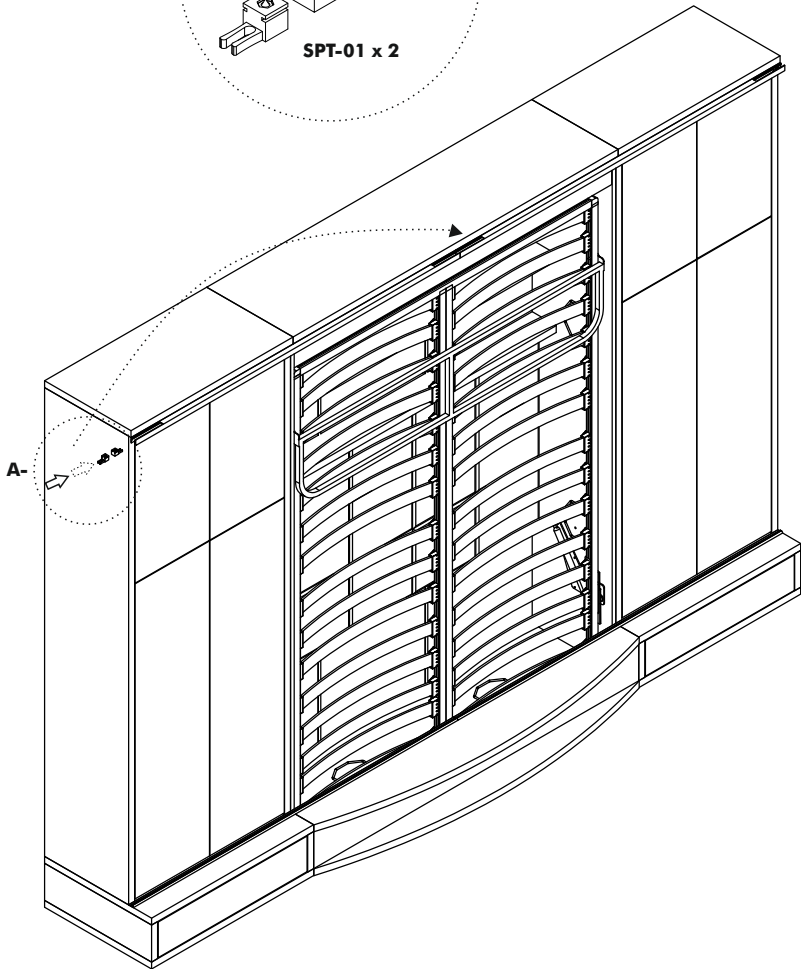

**VIDEO**

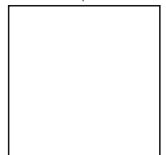

link

STEP 28

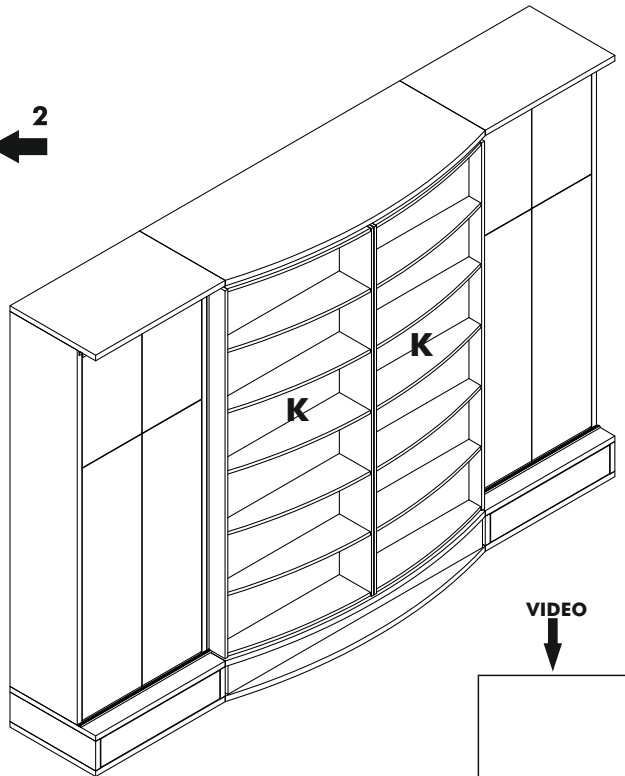
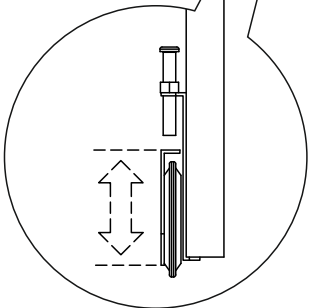
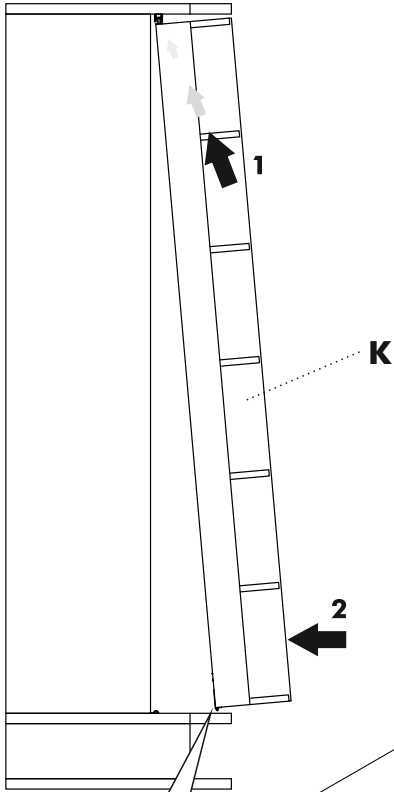

VIDEO

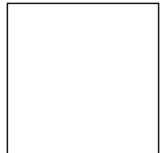

link



**STEP 29**

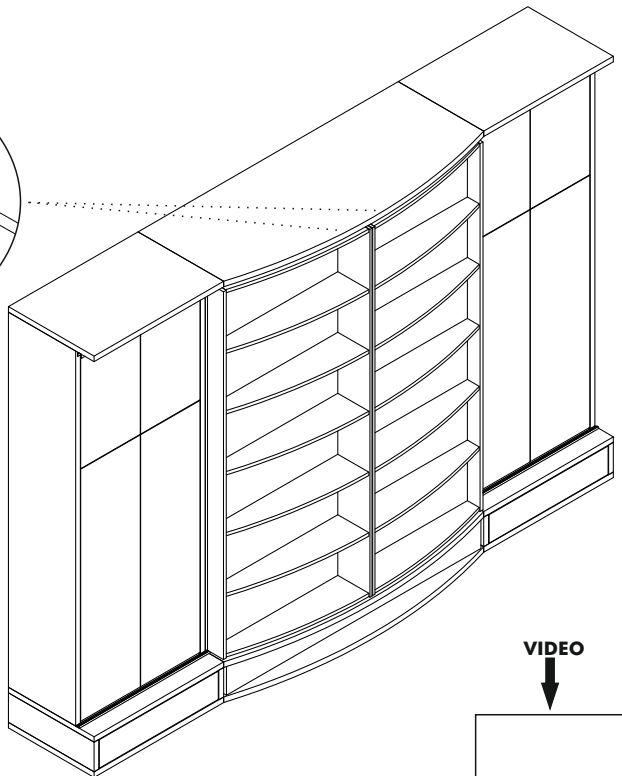
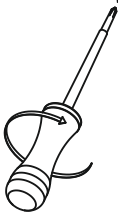
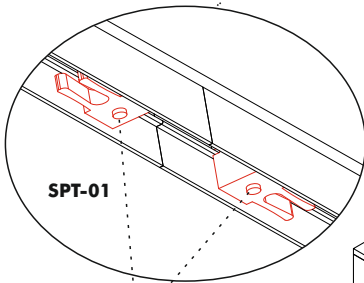
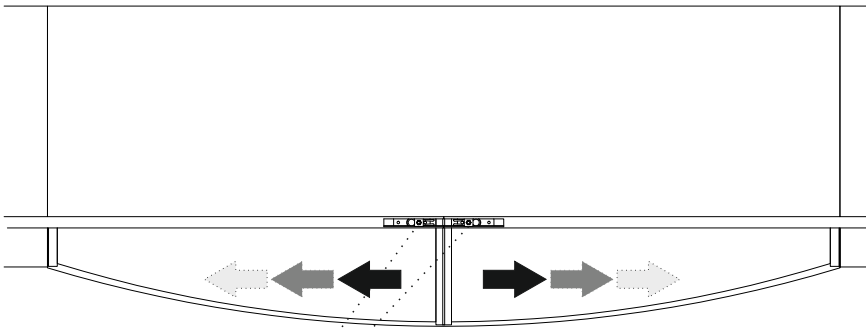

**VIDEO**

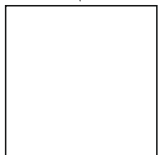

**STEP 30**

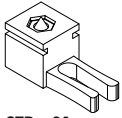

**SPT - 01**

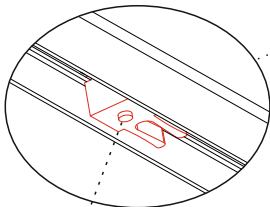
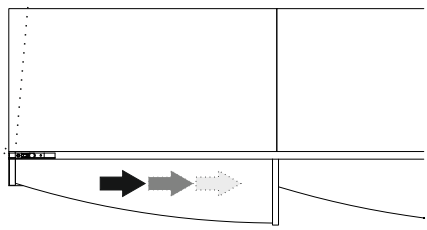
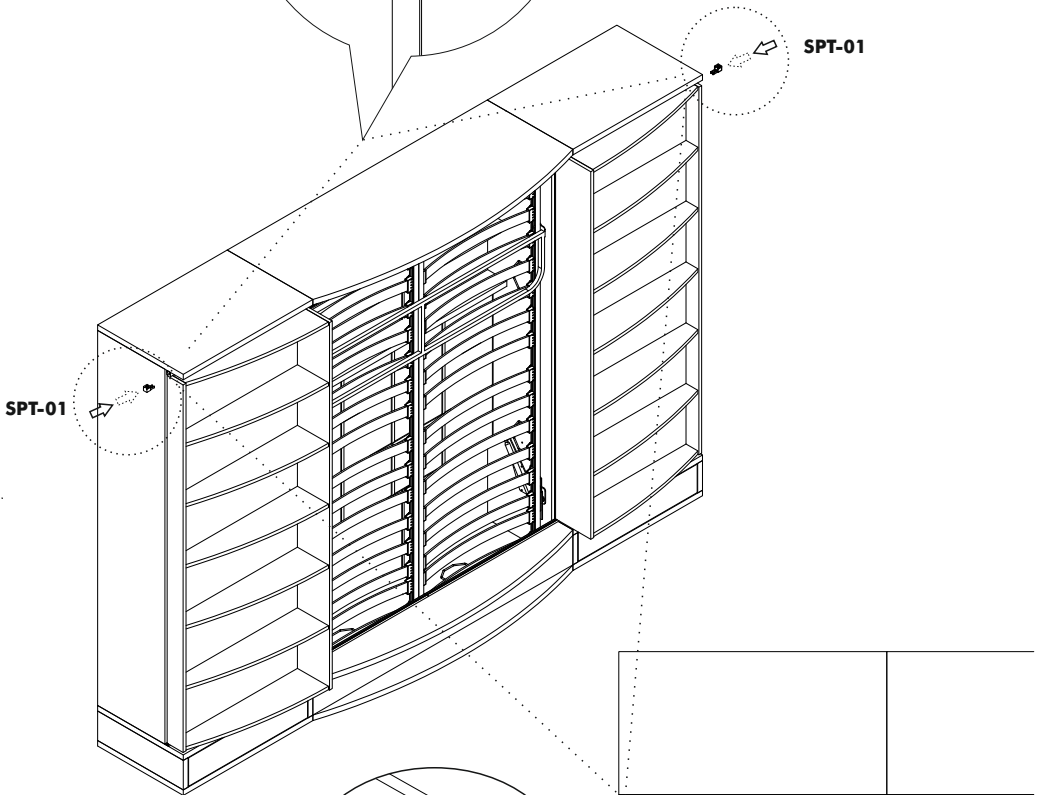
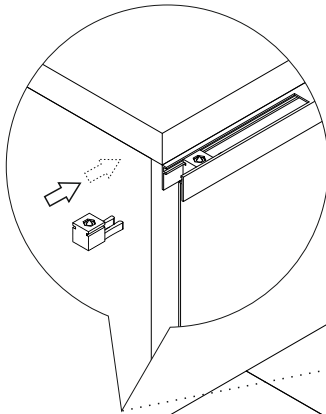

**SPT-01**

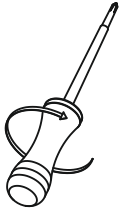

**VIDEO**

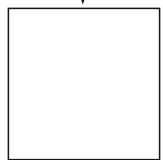

link

## ATTENTION / HOW TO / READ ME / OWNER'S GUIDE

1. When mounting on a regular drywall, furniture must be fastened to wood or metal studs. Solid walls made of brick, concrete or similar strong material are also acceptable. Do not mount furniture to paper-mache or sheetrock (plasterboard) like material without properly fixing to stud.
2. For safety and product longevity you must periodically inspect the mounting and mechanical connections for integrity and tightness. Confirm hardware remains properly affixed and connections snug.
3. Wall Bed mattress thickness may not exceed 8 inches (200mm). Take care to remove pillows and excess blankets before closing. Doing so keeps mechanism free of obstruction and unnecessary stress.
4. Do not lean or rest heavy objects on side or top of furniture. This may cause balance issues and compromise the integrity of your mounting connections.
5. Please use the furniture's beds, desks and shelving as intended. Not designed to be sat, stood, leaned, jumped (etc) on. Improper use may cause personal injury and damage to property.
6. With seasonal humidity change you must inspect interior and exterior of furniture.
7. Single bed models are suitable for the weight of one person. Sleeping by more than one person will cause damage of the product.
8. Before any un-mounting or disassembly please contact Multimo for technical support and instruction. Failure to properly detach risks injury to person and damage to property.
9. For Bunk Beds:
  - a. Always use provided ladder when accessing top bunk.
  - b. Be slow, careful and aware of surroundings when opening top bunk.
  - c. Do not horseplay. Beds are to be slept on only.
  - d. Some have legs that fully extend when open- be aware of where the leg is and will be.



**MULTiMO**

[www.multimo.com](http://www.multimo.com)